

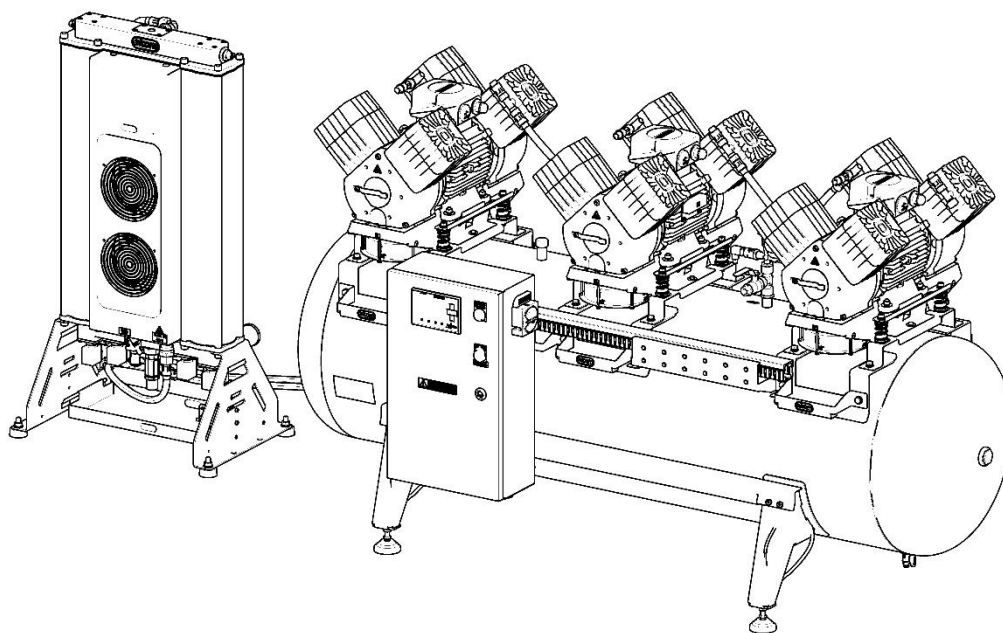

DK50 3X4VR/M

EN USER MANUAL



COMPRESSOR

DK50 3x4VR/M



EKOM spol. s r. o.

Priemyselná 5031/18

SK-921 01 Piešťany

Slovak Republic

tel.: +421 33 7967255

fax: +421 33 7967223

www.ekom.sk

email: ekom@ekom.sk

DATE OF LAST REVISION

11/2025

NP-DK50 3x4VR_M-AD-A-

EN-9_11-2025

112000554-0001

CONTENTS

GENERAL INFORMATION	5
1. CONFORMITY WITH THE REQUIREMENTS OF THE EUROPEAN UNION.....	5
2. SYMBOLS.....	5
3. DEVICE USE.....	6
4. GENERAL SAFETY INSTRUCTIONS.....	7
5. STORAGE AND TRANSPORT CINDITIONS	8
PRODUCT DESCRIPTION	9
6. VARIANTS	9
7. ACCESSORIES	9
8. PRODUCT FUNCTION	10
TECHNICAL DATA	15
INSTALLATION	22
9. INSTALLATION CONDITIONS.....	22
10. COMPRESSOR ASSEMBLY	23
11. PNEUMATIC CONNECTION	26
12. ELECTRICAL CONNECTION	29
13. COMMISSIONING	32
14. PNEUMATIC DIAGRAM.....	33
OPERATION	35
15. SWITCHING ON THE COMPRESSOR	36
16. AD DRYER OPERATING MODES:.....	37
17. SWITCHING OFF THE COMPRESSOR	42
PRODUCT MAINTENANCE	43
18. PRODUCT MAINTENANCE.....	43
19. LONG-TERM SHUTDOWN.....	58
20. DISPOSAL OF DEVICE	58
TROUBLESHOOTING	59
21. REPAIR SERVICE	61

GENERAL INFORMATION

Carefully read this user manual before using the product and carefully store it for future reference. The user manual aids in the proper use, including installation, operation and maintenance, of the product.

The user manual corresponds to the configuration of the product and its compliance with applicable safety and technical standards at the time of its printing. The manufacturer reserves all rights for the

protection of its configuration, processes and names.

The Slovak version represents the original version of the user manual. The translation of the user manual is performed in accordance with the best available knowledge. The Slovak version is to be used in the event of any uncertainties.

The user manual is original and the translation is performed with the best available knowledge.

1. CONFORMITY WITH THE REQUIREMENTS OF THE EUROPEAN UNION

This product conforms to the requirements of the European Union 2006/42/EC, 2014/29/EU, 2014/35/EU, 2014/30/EU, 2011/65/EU and is safe if used in compliance with the intended use and if all safety

instructions are followed.

User manual is in compliance with requirements of Directive 2006/42/EC.

2. SYMBOLS

The following symbols and marks are used in the User manual, on the device and its packaging:



General warning



Warning - risk of electric shock



Warning - compressor is controlled automatically



Warning - hot surface



General caution



Refer to instruction manual



CE – marking



Serial number













Article number



Protecting earthing



Terminal for ground connection

	Fuse
	Compressed air inlet - dryer
	Compressed air outlet - dryer
	Control wire input
	Package handling label – fragile
	Package handling label – this side up
	Package handling label – keep dry
	Package handling label – temperature limits
	Package handling label – limited stacking
	Package label – recyclable material
	Manufacturer

3. DEVICE USE

3.1. Intended use

The compressor is used as source of clean oil-free compressed air intended to be used in industry and laboratories, where parameters and properties of the compressed air are suitable.

The compressor is exclusively intended to compress air without content of explosive or chemically unstable substances.

The compressor is intended for operation in clean and dry rooms.

3.2. Incorrect use



Contamination risk.

Air from the compressor is without additional treatment not suitable for breathing and direct contact with food.



Explosion risk.

The product is not intended for operation in rooms with explosion risk.

The compressor must not be used to compress aggressive gases.

The compressor must not be operated in premises with occurrence of flammable vapors.

The compressor must not be operated in other conditions as mentioned in Technical data.

Any other use of the product beyond the intended use is considered as incorrect use. The manufacturer is not responsible for any damages or injuries as a result of incorrect use or disobedience to instructions stated in this User manual. All risks shall be solely borne by the user/operator.

4. GENERAL SAFETY INSTRUCTIONS

The product is designed and manufactured so that any risks connected with its use are minimized and the product is safe for the user and surrounding when used according to the intended use and the instructions stated below are followed.

4.1. Required qualification of the personnel

- Each user must be trained by the manufacturer or an organization authorized by the manufacturer or instructed on the device operation by other trained user.
- Installation, new settings, changes, extensions and repairs of the product may be performed by the manufacturer or an organization authorized by the manufacturer (hereinafter qualified technician).
 - Otherwise the manufacturer is not responsible for safety, reliability and correct functioning of the product.

4.2. General instructions

- When operating the compressor, all acts and local regulations valid in the place of use must be observed. The operator and user are responsible for following the applicable regulations.
- Before every use, the user must check, if the device is functioning correctly and safely. Before building the compressor in other devices, the supplier must assess, if the supplied air and construction of the device comply with the requirements of the specified intended use. Taking this into account, follow the product technical data. Assessment of conformity shall be performed by the manufacturer – supplier of the final product.

4.3. Protection from dangerous voltage and pressure

- The equipment may only be connected to a properly installed socket connected to earth (grounded).
- Before the product is plugged in, make sure that the mains voltage and frequency stated on the product are the same as the power mains.
- Check for any damage to the connected compressed air system and electrical circuits before use. Replace damaged pneumatic and electrical conductors immediately.
- Immediately disconnect the product from the mains (remove the power cord from the socket) in hazardous situations or when a technical malfunction occurs.
- Never adjust or use the safety valve to release the air pressure in the air tank.
- Never adjust or use pressure relief valves to release air pressure from the device.

4.4. Original spare parts and accessories

- Only the use of original parts guarantees the safety of operating personnel and flawless operation of the product itself. Only accessories and replacement parts specified in the technical documentation or expressly approved by the manufacturer may be used.
- The warranty does not cover damage resulting from the use of other accessories and replacement parts as specified or recommended by the manufacturer and the manufacturer has no related liability.

5. STORAGE AND TRANSPORT CINDITIONS

The compressor is shipped from the manufacturer in transport packaging. This protects the product from damage during transport.



Potential for damage to pneumatic components.

The compressor must be transported only when all air has been vented. Before moving or transporting the compressor, release all the air pressure from the tank and pressure hoses, from dryer chambers and drain condensate from the tank and from the condensate separator on the dryer.



Storing or shipping the equipment in any conditions other than those specified below is prohibited.



Keep the original factory packaging in case the device needs to be returned Use the original factory packaging during transport as it provides optimum protection for the product. . If it is necessary to return the product during the warranty period, the manufacturer is not liable for damages caused by improper packaging.



The compressor is shipped in a vertical position and must be secured using transport straps.



Protect the compressor from humid and dirty environments and extreme temperatures during transport and storage. Do not store near any volatile chemical substances.



If not, please dispose of the original packaging material in an environmentally-friendly way. The packaging cardboard can be recycled with old paper.

5.1. Ambient conditions

Products may only be stored and transported in vehicles that are free of any traces of volatile chemicals under the following climactic conditions:

Temperature

–25°C to +55°C, 24 h at up to +70°C

Relative humidity

max. 90% (non-condensing)

PRODUCT DESCRIPTION

6. VARIANTS

The compressor is manufactured according to its intended application in the following variants:

DK50 3x4VR/M

Comprised of module:

- 1 Compressor module
- 2 Adsorption dryer module AD750E

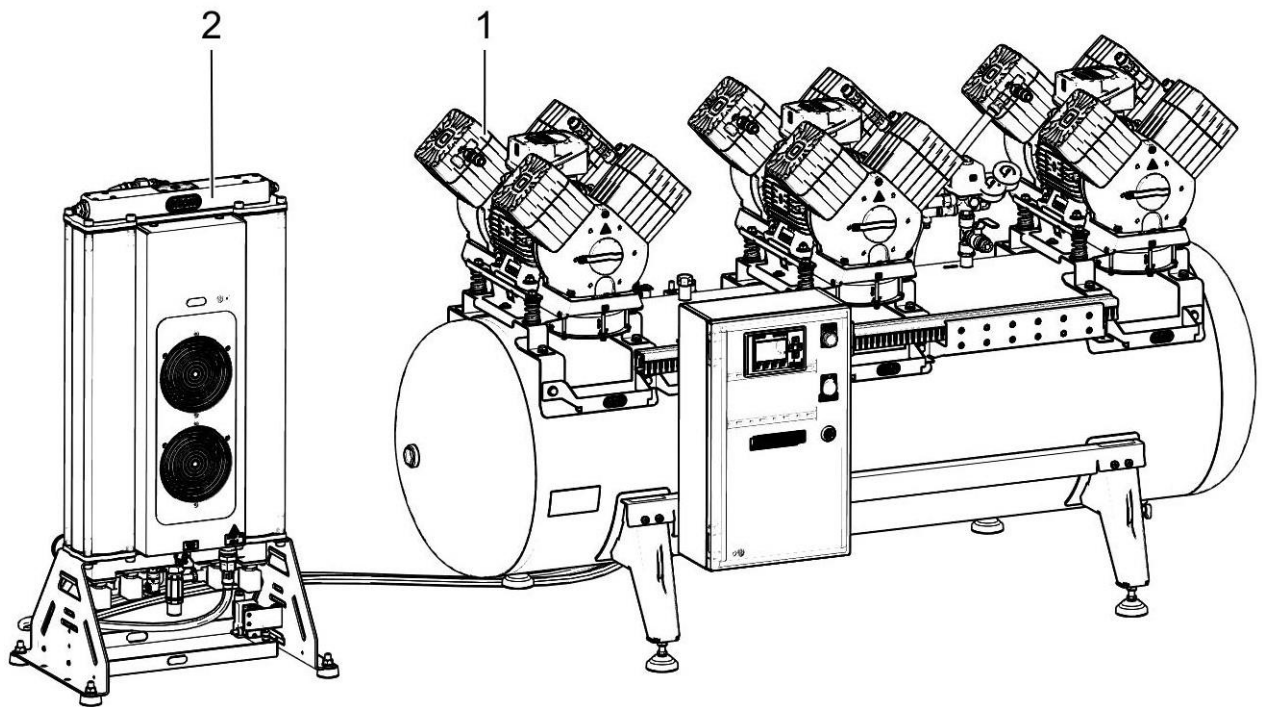

DK50 3x4VR/M



The compressed air supplied by the compressor is unsuitable for use with artificial lung ventilation devices without further filtration.

7. ACCESSORIES

Accessories that are not included in the standard order must be ordered separately.;

Set of compressed air outlet filters

The compressor may be equipped with a set of filters if specified. The filter set may be

equipped with an air pressure regulator.



Where a different level of air filtration is required, this requirement must be agreed upon with the supplier and specified in the order.

Type	Use	Level of filtration (µm)	Bypass function *	Article number
FS 40F		1		604014119-000
FS 40M	DK50 3x4VR	1+0.1	no	604014119-004
FS 40S		1+0.01		604014119-024
FS 40AH		1+AC+HC(0.01)		604014119-005

*) These FS do not contain a filter bypass, which will ensure a continuous flow of air when replacing the filter element. Such a set must be ordered separately.

pressure regulator of the compressed air outlet if specified. The regulator must be selected according to the application to the filter set, or separately. The regulator shall ensure constant pressure at the outlet.

Filter set regulator assembly

The compressor may be equipped with a

Type	Use	Article number
Regulator REG 16	DK50 3x4VR ^{a)}	447000001-057
Regulator complete	DK50 3x4VR ^{b)}	604014125-000

^{a)} individual regulator set

^{b)} regulator set for filter set

Filter set brackets



A suitable bracket must be ordered for every filter set.

Type	Use	Article number
Compressor-mounter bracket	DK50 3x4VR	603014136-000
Wall-mounted bracket		603014120-000

8. PRODUCT FUNCTION

8.1. Compressor with adsorption dryer

The compressor air pumps (1) draw air through the inlet filters (8) and compress it through non-return valves (3) into a common manifold, from which it is routed to the external adsorption dryer (9) through a connecting hose. From the inlet to the dryer module, the air is first cooled in the integrated cooler (14) and then moves through the condensate separator (40), entering the active chamber with adsorbent (16), where the air is dried. A portion of the air is fed into the second, regeneration chamber, where this air is used to remove moisture from the adsorbent, after

which it is released through the silencer (38). The active chamber switches on a cyclical basis. The dry and filtered air then passes through a non-return valve (31) and into the air tank (2), where it is ready for further use.

Check the dryer and the air tank non-return valve (31) to ensure they are operating properly if the pressure relief valve (37) continues to open.



Adjusting the opening pressure of the pressure relief valve or other modification of this valve is prohibited!

Descriptions for figures 1 - 3

- | | | | |
|----|------------------------------|----|---------------------------------|
| 1 | Air pump | 23 | Circuit breaker |
| 2 | Air tank | 24 | Contactora |
| 3 | Non-return valve | 25 | Motor circuit breaker |
| 4 | - | 26 | Power supply |
| 5 | Safety valve | 27 | Logo DM8 |
| 6 | Pressure gauge | 28 | Logo text display |
| 7 | Drain valve | 29 | Pressure relief valve |
| 8 | Inlet filter | 30 | Common air pump outlet manifold |
| 9 | Adsorption dryer | 31 | Air tank non-return valve |
| 10 | Compressor fan | 32 | Adjustable foot |
| 11 | Condensate collection vessel | 33 | Regeneration solenoid valve |
| 12 | Magnetic holder | 34 | Regeneration solenoid valve |
| 13 | Air outlet | 35 | Inlet solenoid valve |
| 14 | Cooling module | 36 | Inlet solenoid valve |
| 15 | Inlet valve module | 37 | Pressure relief valve |
| 16 | Dryer chamber | 38 | Noise silencer |
| 17 | Main switch | 39 | Compressed air inlet |
| 18 | - | 40 | Condensate separator |
| 19 | Outlet module | 41 | Pressure gauge |
| 20 | Connector | 42 | Automatic condensate drain |
| 21 | Red indicator | 43 | Dryer pan |
| 22 | Logo CPU | 44 | Air outlet |

Fig. 1: DK50 3x4VR/M – Compressor with adsorption dryer

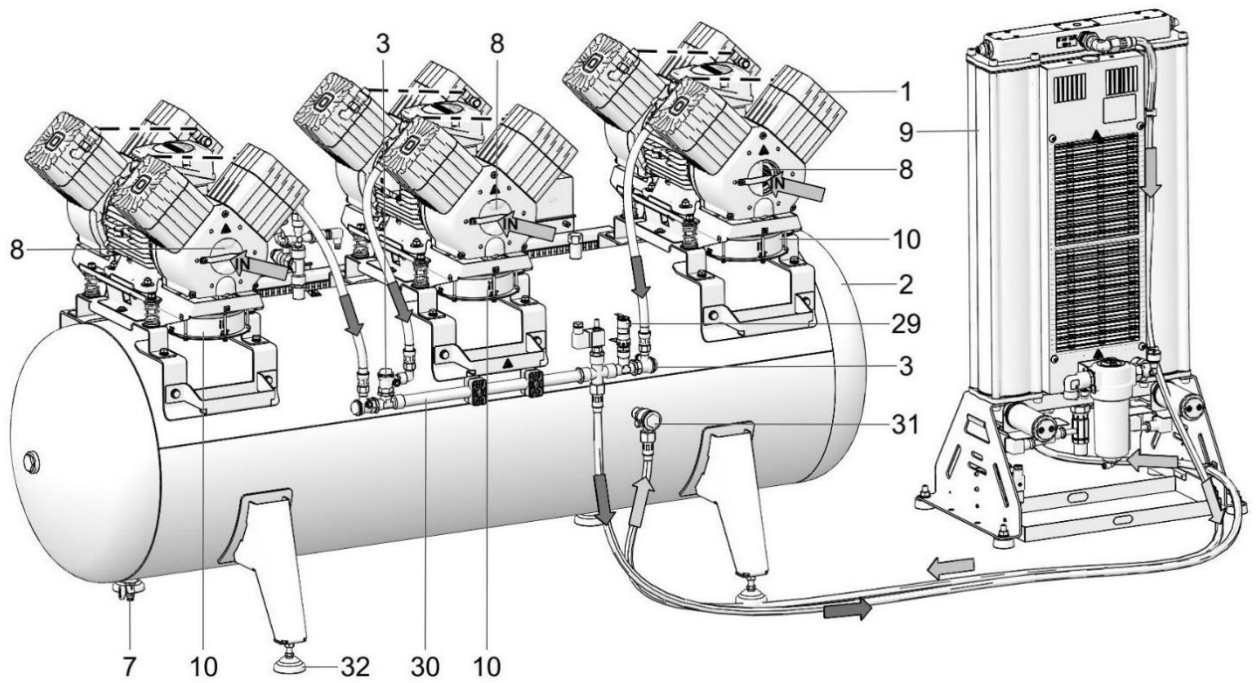
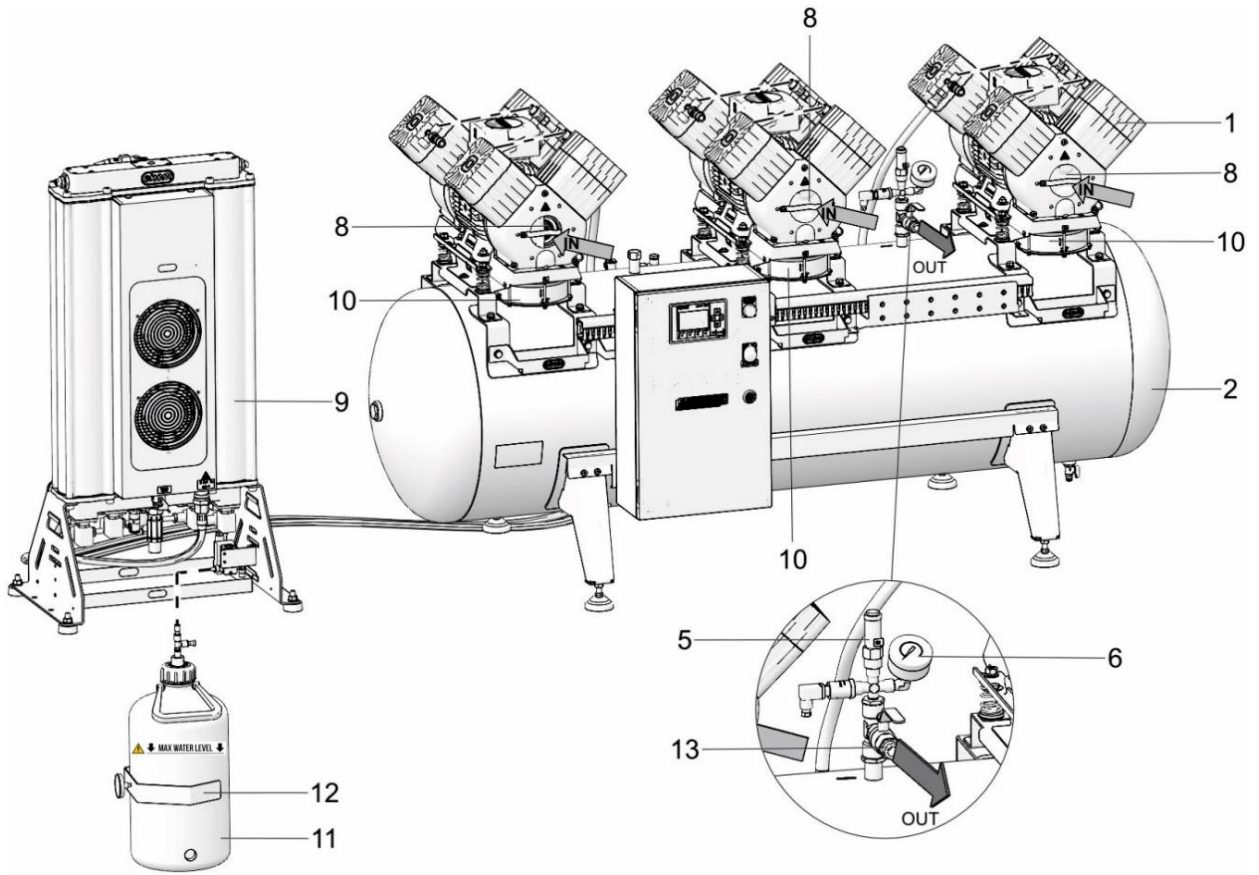

Fig. 2: Adsorption dryer

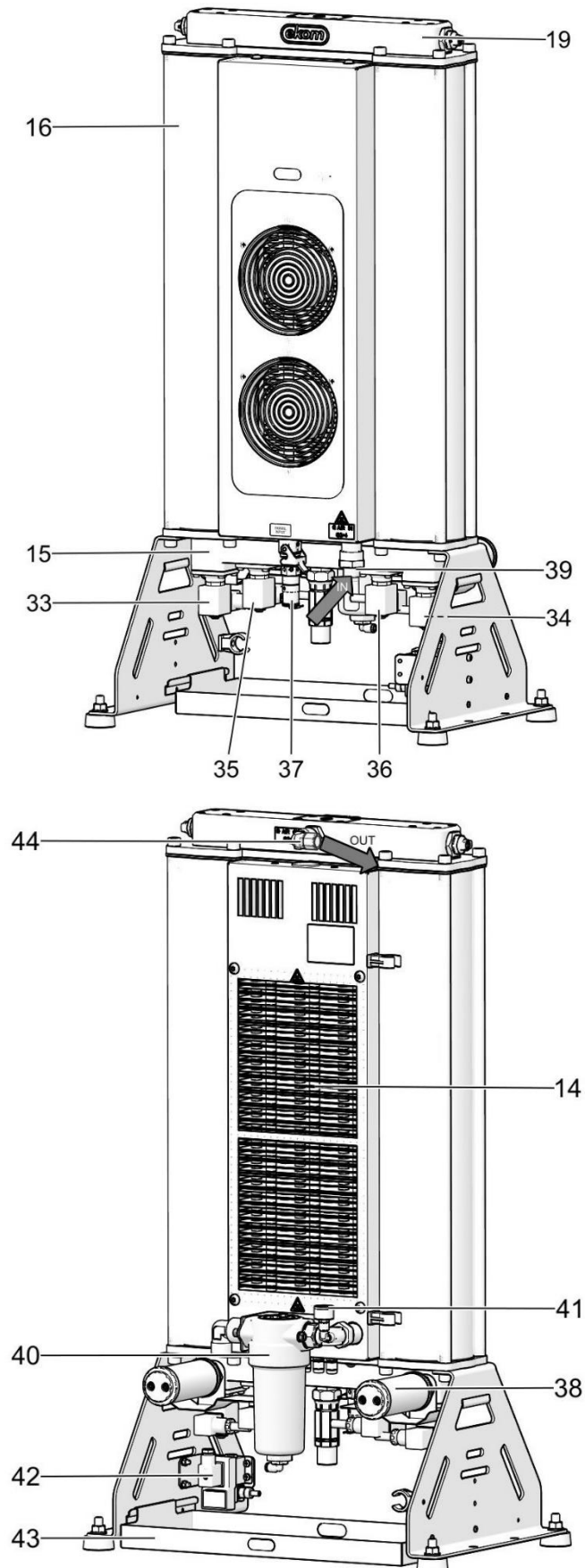
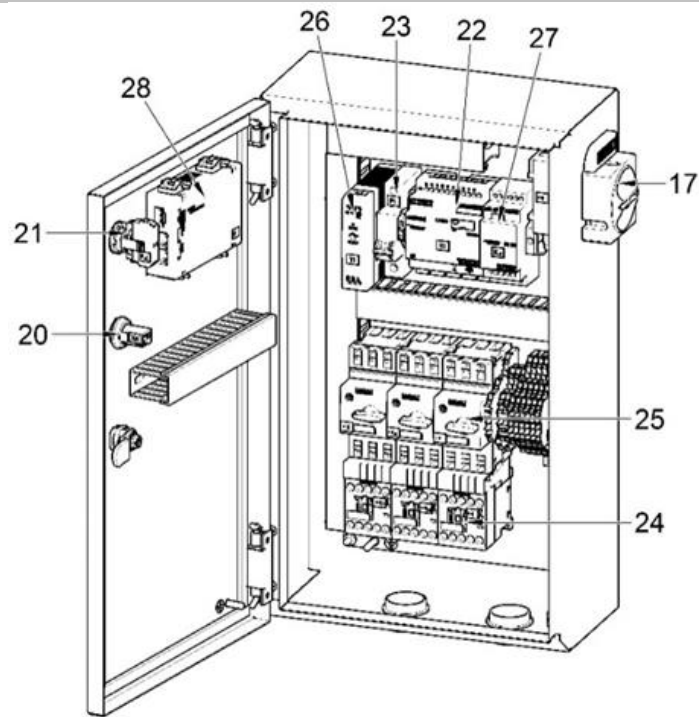

Fig. 3: Switchboard

TECHNICAL DATA

Compressors are designed for operation in dry, ventilated and dust-free indoor rooms under the following climactic conditions:

Temperature

+5°C to +40°C

Relative humidity

max. 70%

Working pressure 6 – 8 bar		DK50 3x4VR/M
Nominal voltage, Frequency ^{a)}	V, Hz	3x400, 50
Capacity at 6 bar (FAD) -20°C	l/min	680
Working pressure ^{b)}	bar	6.0 – 8.0
Rated current	A	15.9
Main circuit protection device rating	A	16
Main electrical feeder	mm ²	5C x 1.5
Enclosure		IP10
Motor power	kW	3x2.2
Air tank volume	l	290
Maximum operating pressure of safety valve	bar	10.0
Noise level at 5 bar (L _{pA})	dB	≤80
Operating mode	%	S1-100
PDP drying performance at 7 bar ^{d)}	°C	≤ -20
Time to fill air tank from 0 to 7 bar	s	≤190
Required cooling air changes in space	m ³ /h	1850
Dimensions (net) w x d x h	mm	2520x800x1025
Dimensions – compressor w x d x h	mm	1780x800x1025
Dimensions – AD750E dryer w x d x h	mm	530x350x965
Net weight ^{c)}	kg	327
Net weight – compressor ^{c)}	kg	283
Net weight - dryer ^{c)}	kg	44

^{a)} Specify the compressor version when ordering

^{b)} Consult any other range of pressure with the supplier

^{c)} Weight is indicative and only applies to the product without accessories

^{d)} Applies to ambient temperatures of <30°C PDP – pressure dew point

Working pressure 6 – 8 bar		DK50 3x4VR/M
Nominal voltage, Frequency ^{a)}	V, Hz	3x400, 50
Capacity at 6 bar (FAD) -40°C	l/min	650
Working pressure ^{b)}	bar	6.0 – 8.0
Rated current	A	15.9
Main circuit protection device rating	A	16
Main electrical feeder	mm ²	5C x 1.5
Enclosure		IP10
Motor power	kW	3x2.2
Air tank volume	l	290
Maximum operating pressure of safety valve	bar	10.0
Noise level at 5 bar (L _{pA})	dB	≤80
Operating mode	%	S1-100
PDP drying performance at 7 bar ^{d)}	°C	≤ -40
Time to fill air tank from 0 to 7 bar	s	≤200
Required cooling air changes in space	m ³ /h.	1850
Dimensions (net) w x d x h	mm	2520x800x1025
Dimensions – compressor w x d x h	mm	1780x800x1025
Dimensions – AD750E dryer w x d x h	mm	530x350x965
Net weight ^{c)}	kg	327
Net weight – compressor ^{c)}	kg	283
Net weight - dryer ^{c)}	kg	44

^{a)} Specify the compressor version when ordering

^{b)} Consult any other range of pressure with the supplier

^{c)} Weight is indicative and only applies to the product without accessories

^{d)} Applies to ambient temperatures of <30°C PDP – pressure dew point

Dependence of compressor output on working pressure

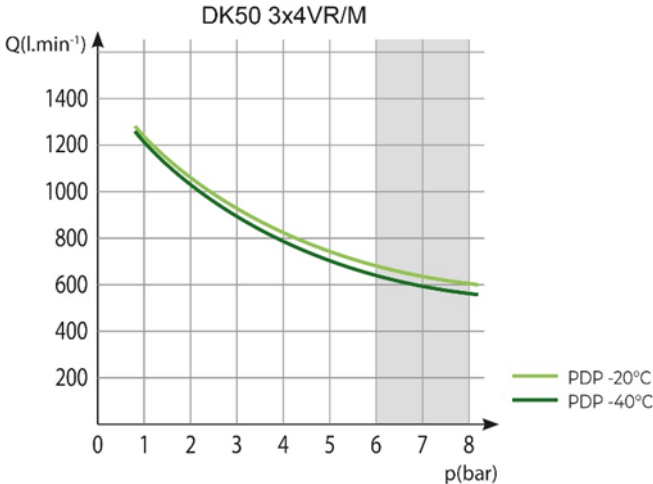

Working pressure 8 – 10 bar		DK50 3x4VR/M
Nominal voltage, Frequency ^{a)}	V, Hz	3x400, 50
Capacity at 8 bar (FAD) -20°C	l/min	520
Working pressure ^{b)}	bar	8.0 – 10.0
Rated current	A	16
Main circuit protection device rating	A	16
Main electrical feeder	mm ²	5C x 1.5
Enclosure		IP10
Motor power	kW	3x2.2
Air tank volume	l	290
Maximum operating pressure of safety valve	bar	12.0
Noise level at 5 bar (L _{pA})	dB	≤80
Operating mode	%	S1-100
PDP drying performance at 7 bar ^{d)}	°C	≤ -20
Time to fill air tank from 0 to 7 bar	s	≤ 240
Required cooling air changes in space	m ³ /h	1850
Dimensions (net) w x d x h	mm	2520x800x1025
Dimensions – compressor w x d x h	mm	1780x800x1025
Dimensions – AD750E dryer w x d x h	mm	530x350x965
Net weight ^{c)}	kg	327
Net weight – compressor ^{c)}	kg	283
Net weight - dryer ^{c)}	kg	44

^{a)} Specify the compressor version when ordering

^{b)} Consult any other range of pressure with the supplier

^{c)} Weight is indicative and only applies to the product without accessories

^{d)} Applies to ambient temperatures of <30°C PDP – pressure dew point

Dependence of compressor output on working pressure

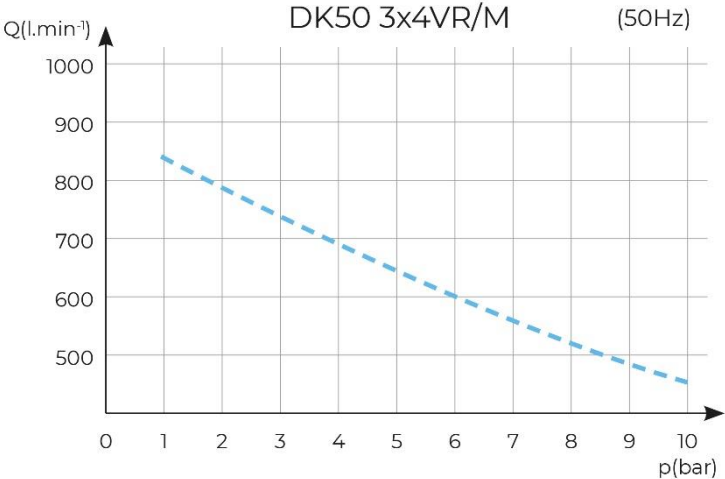

Working pressure 8 – 10 bar		DK50 3x4VR/M
Nominal voltage, Frequency ^{a)}	V, Hz	3x400, 50
Capacity at 8 bar (FAD) -40°C	l/min	500
Working pressure ^{b)}	bar	8.0 – 10.0
Rated current	A	16
Main circuit protection device rating	A	16
Main electrical feeder	mm ²	5C x 1.5
Enclosure		IP10
Motor power	kW	3x2.2
Air tank volume	l	290
Maximum operating pressure of safety valve	bar	12.0
Noise level at 5 bar (L _{pA})	dB	≤80
Operating mode	%	S1-100
PDP drying performance at 7 bar ^{d)}	°C	≤ -40
Time to fill air tank from 0 to 7 bar	s	≤ 250
Required cooling air changes in space	m ³ /h	1850
Dimensions (net) w x d x h	mm	2520x800x1025
Dimensions – compressor w x d x h	mm	1780x800x1025
Dimensions – AD750E dryer w x d x h	mm	530x350x965
Net weight ^{c)}	kg	327
Net weight – compressor ^{c)}	kg	283
Net weight - dryer ^{c)}	kg	44

^{a)} Specify the compressor version when ordering

^{b)} Consult any other range of pressure with the supplier

^{c)} Weight is indicative and only applies to the product without accessories

^{d)} Applies to ambient temperatures of <30°C PDP – pressure dew point

Dependence of compressor output on working pressure

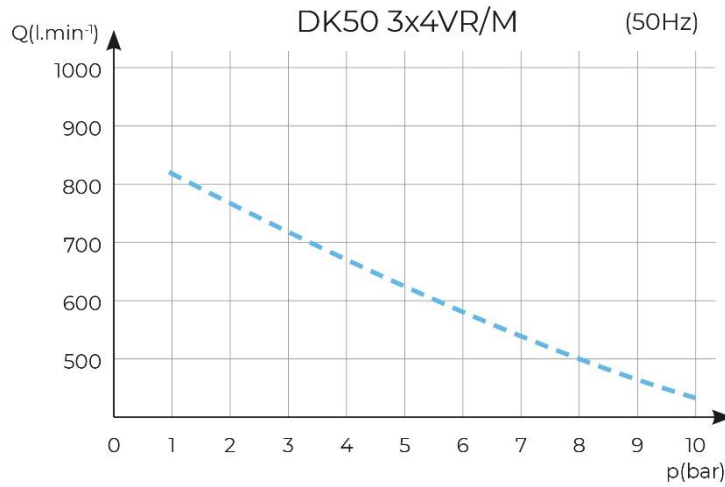

FAD correction of capacity for altitude

Capacity given in the form of FAD („Free Air Delivery“) applies to the following conditions:

Altitude	0 m.n.m.	Temperature	20°C
Atmospheric pressure	101325 Pa	Relative humidity	0%

To calculate FAD compressor capacity in dependence on altitude, it is necessary to apply correction factor according to the following table:

Altitude [m.n.m.]	0 -1500	1501 - 2500	2501 - 3500	3501 - 4500
FAD correction factor	1	0.8	0.71	0.60

INSTALLATION



Risk of incorrect installation.

Only a qualified technician may install the compressor and place it into operation for the first time. Their duty is to train operating personnel on the use and maintenance of the equipment. An entry is made in the equipment installation record to certify installation and operator training (see warranty card).

9. INSTALLATION CONDITIONS

- The compressor may only be installed and operating in dry, well-ventilated and clean environments under the conditions specified in the Technical Data chapter.



Risk of damage to the device.

The equipment may not be operated outdoors or in otherwise wet or damp environments.



Risk of explosion.

Do not use the equipment in the presence of explosive gases, dust or combustible liquids.

- The compressor must be installed so that it is accessible at all times for operating and maintenance. Please ensure that the nameplate on the device is readily accessible.
- The compressor must stand on a flat, sufficiently stable base (be aware of the weight of the compressor, see the Technical Data chapter)
- The compressor on the operator's side must be at least 70 cm from the wall to allow air flow for cooling purposes and to ensure the safety of the operator and maintenance personnel.
- Approximately 70% of the electrical energy used by the compressor aggregates is converted to heat and therefore the rooms in which a compressor assembly is installed must have additional ventilation to

provide sufficient air exchange for cooling purposes (see the technical data).

Environmental requirement:

Temperature	+5 to +40°C
Relative humidity	70%
Max. absolute humidity	15g/m ³



Burn or fire hazard! Caution. Hot surface.

Portions of the compressor, dryer and connecting hoses between the dryer and compressor may be hot and reach hazardous temperatures during compressor operation that may harm materials or operating staff.



High temperature hazard.

The placement of air flow impediments upstream or downstream of the cooler is prohibited. The temperature of internal and external parts of the cooler may be hot and reach hazardous temperatures.



You may notice a “new product” odour when you first place the product into service (for a short period of time). This odour is temporary and does not impede the normal use of the product. Ensure the space is properly ventilated after installation.

Fig. 4: Equipment installation

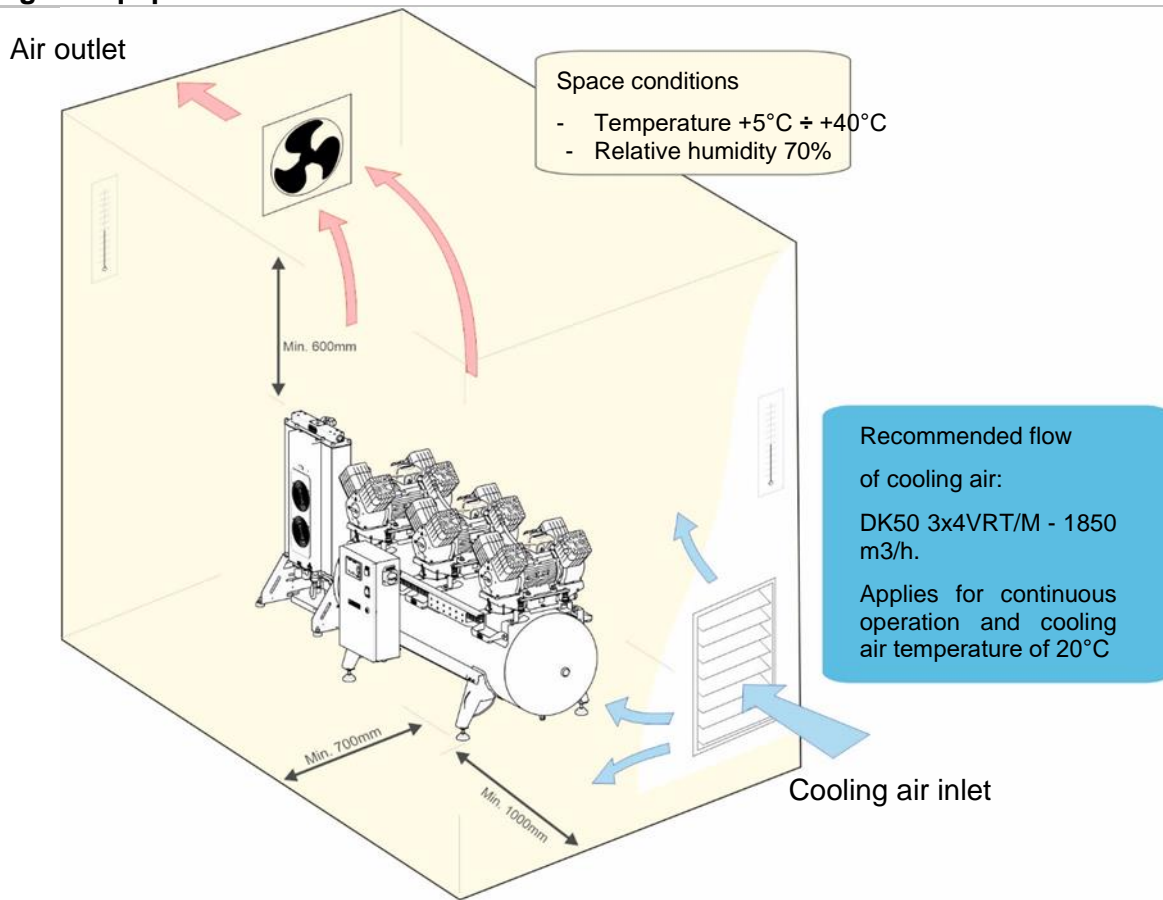

10. COMPRESSOR ASSEMBLY

10.1. Handling and releasing the compressor

- Unpack the compressor assembly (compressor and dryer module) from the packaging and remove the transport anchors from the pallet. Fixation of the compressor and dryer module to the pallet.
- Use a fork lift truck or similar hoisting equipment to handle and position the product.
- Position the compressor module at the site of installation (Fig. 5).
- Remove the transport beams (1).
- Position and level the compressor assembly at its final location.

Fig. 5: Handling the compressor

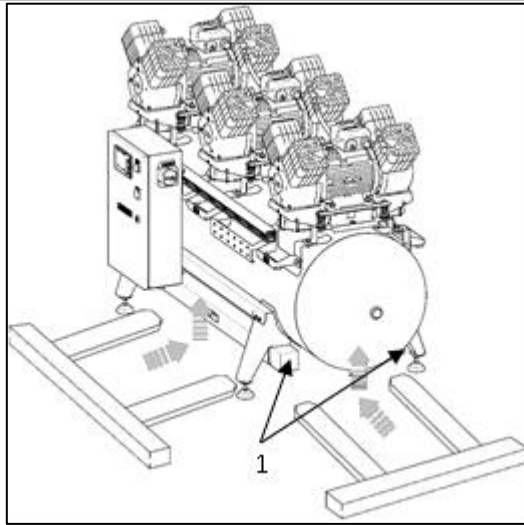

- Remove the transport stabilisers from the air pumps – 6 mounts (Fig. 6).



Prior to installation, ensure that the compressor is free of all transport packaging and stabilizers to avoid any risk of damage to the product.

Remove all devices used to secure the aggregates once the compressor is installed and levelled at the site of final installation.

Fig. 6: Releasing the air pumps

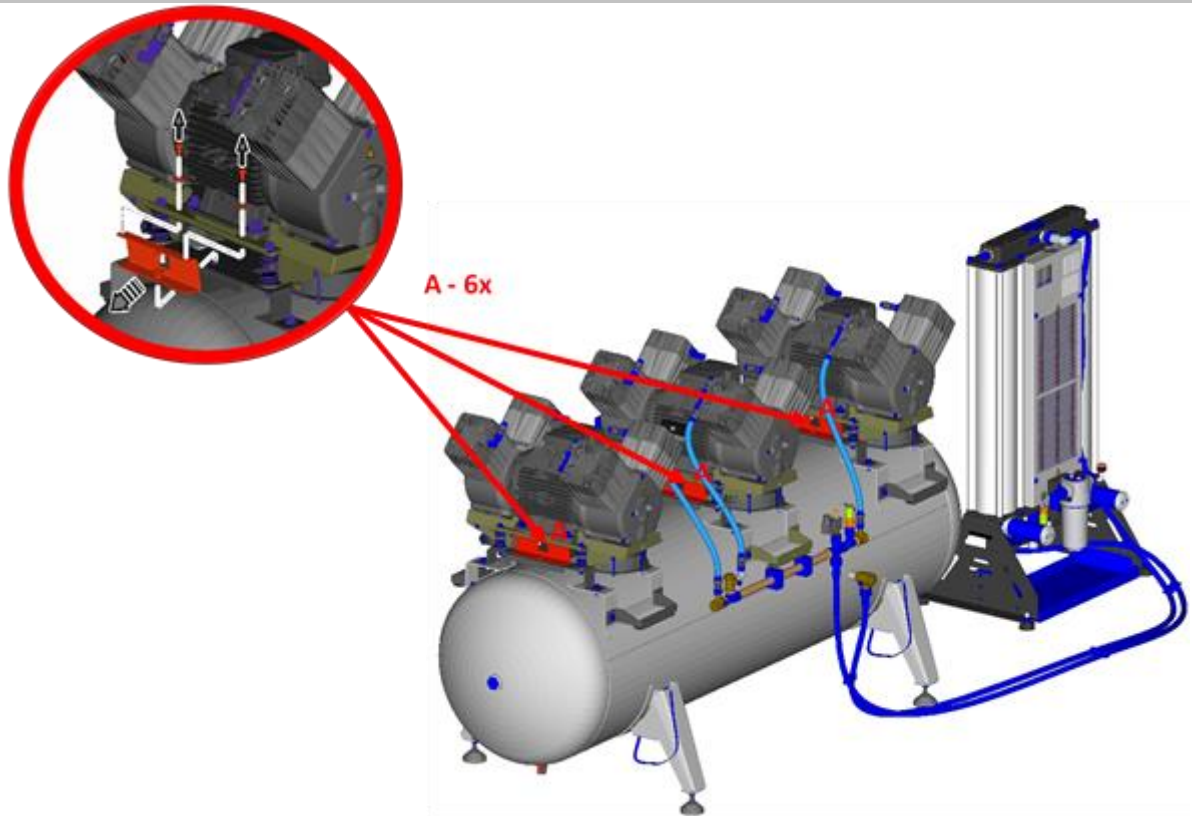

Assembly of the AD dryer

- Remove the dryer from the packaging.
- Install the dryer in its operating position (Fig. 7).

Manipulation



At least two persons are needed to handle the equipment.

Integrated handles are installed on the lower brackets on the product. Each person must grasp the equipment with one hand on a handle and the other behind the dryer chamber when moving the equipment.

Fig. 7: Handling the dryer

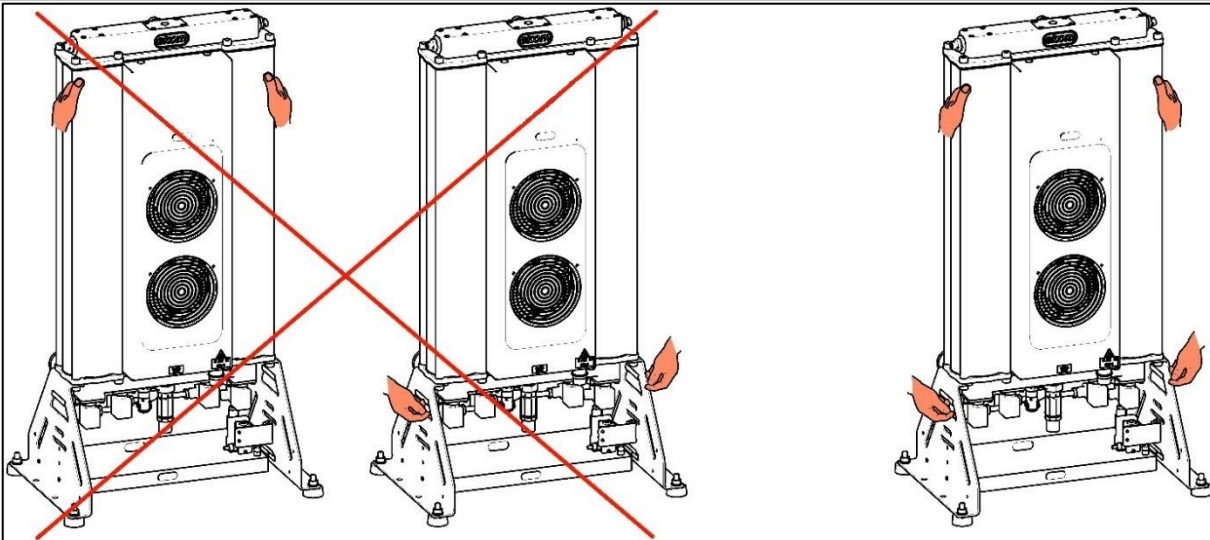

11. PNEUMATIC CONNECTION

11.1. Connecting the dryer to the compressor

Connect the compressor assembly using the connecting hoses (included with delivery):

- Connecting hose (A) is routed from the

compressor outlet (1) to the dryer inlet (2) and is routed together with hose B using double clips (3).

- Connecting hose (B) is routed from the dryer outlet (4) to the air tank inlet (5) and is connected to the dryer (6) using clips.

Fig. 8: Connecting the dryer to the compressor

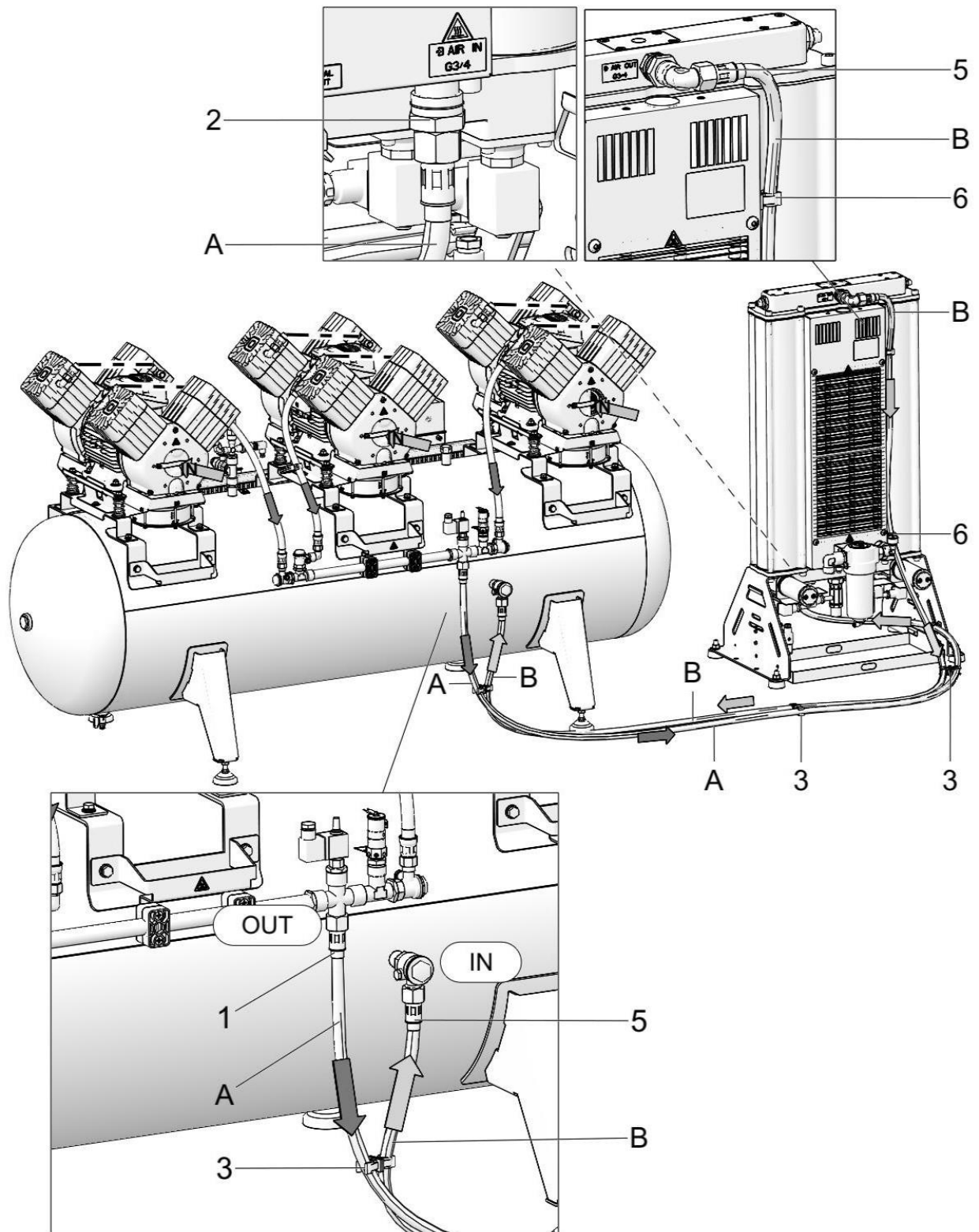



Risk of fire and electric shock.

Ensure the power cord does not touch hot parts of the equipment or connecting hoses.

AD dryer compressed air inlet

- Connect the compressed air outlet from the air tank to the dryer inlet (1).

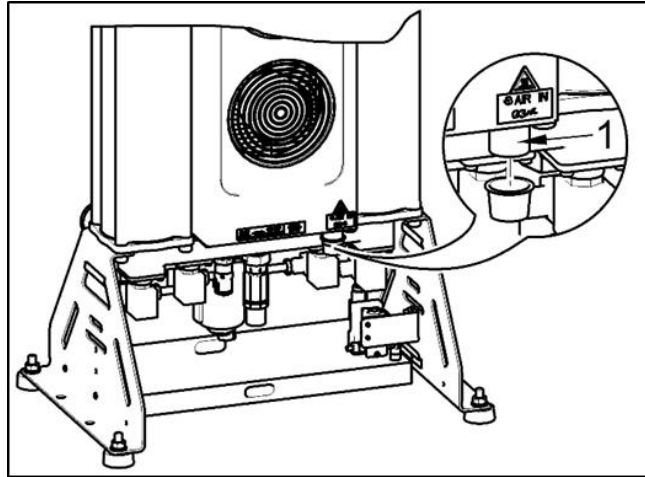

Fig. 9: Air inlet to the dryer



**Burn or fire hazard! Caution!
Hot surface!**

When installing connecting hose (Fig. 8) at the air inlet to the dryer, please note the hose and the manifold on the compressor may be hot and reach hazardous temperatures that may harm materials or operating staff.

AD dryer compressed air outlet

- Connect the outlet from the dryer (1) to the air inlet on the compressor air tank.

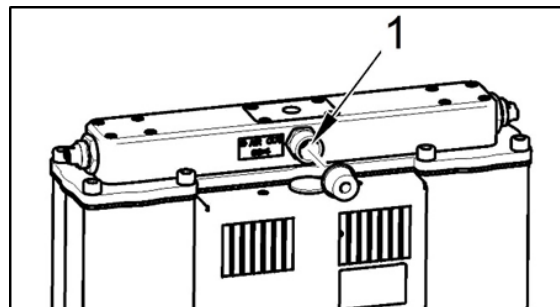

Fig. 10: Air outlet from the dryer

Compressed air outlet from the compressor

- A G1/2" female threaded end ball valve is installed on the compressed air outlet from the air tank (M).

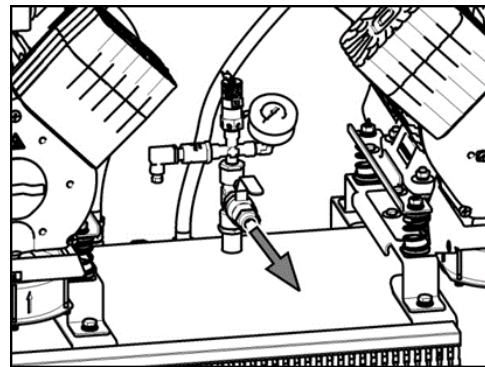

Fig. 11: Air outlet from the air tank

Condensate outlet from dryer

- Connect a hose to the outlet (1) from the automatic condensate drain (2) to drain

pipng or to the provided collection vessel.

A noise silencer is recommended when connecting directly to drain piping.

Fig. 12: Codensate drain

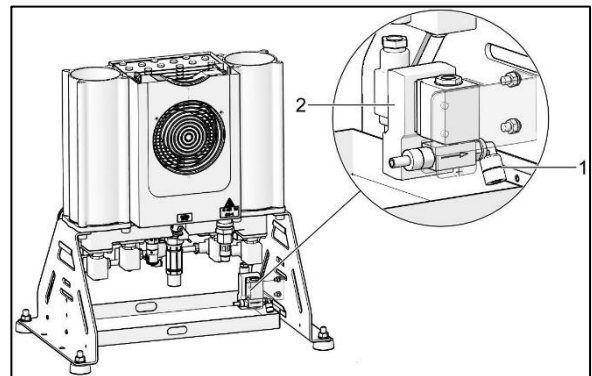
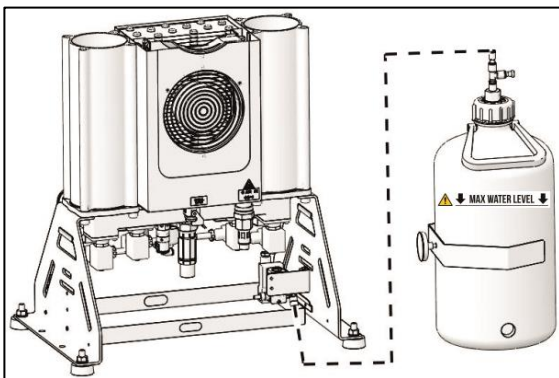

Risk of damage to pneumatic components.

Air hoses must not be broken.

12. ELECTRICAL CONNECTION

- Connect the compressor module to the dryer module using the W22 cable (Fig. 13). The connecting cable must be

protected with a suitable cable guard to prevent damage when routed on the floor.

Fig. 13: Connecting the W22 connection cable

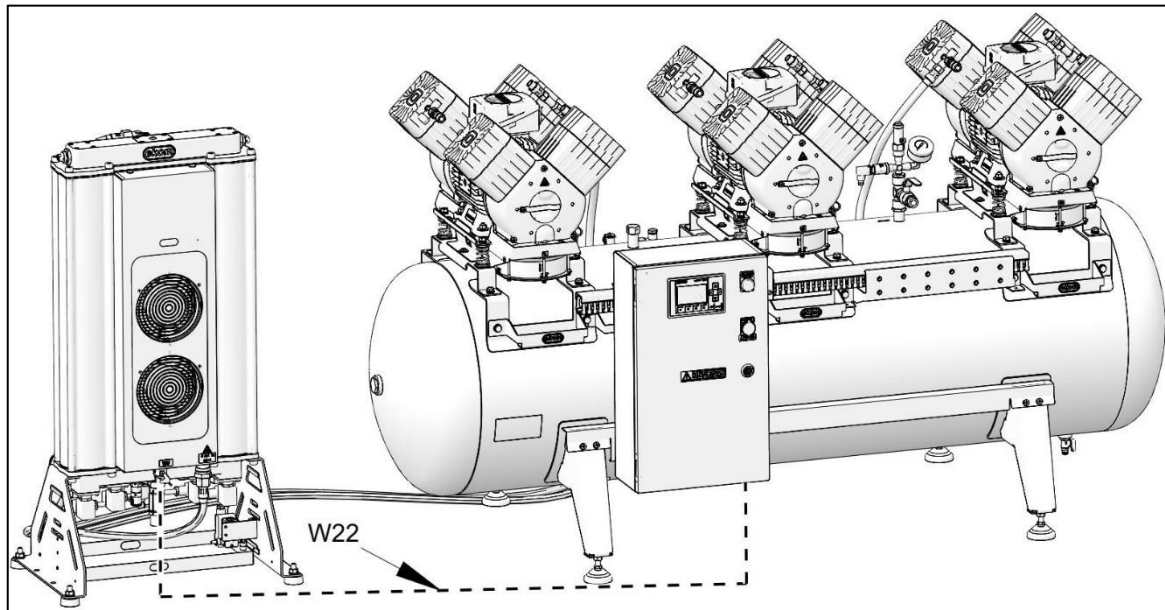
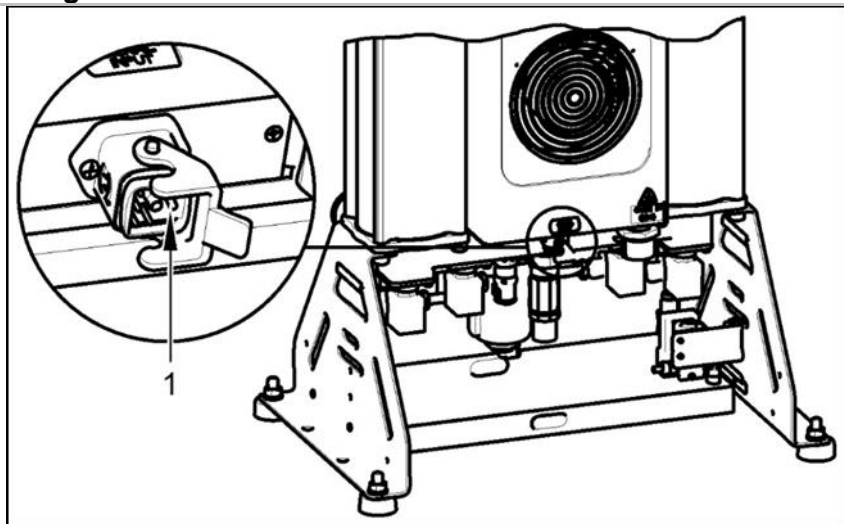

Fig. 14: Connecting the control signal

1. Connector Harting



Risk of fire and electric shock.
Electrical cable must not be in contact with hot compressor components.



Risk of electric shock.
It is necessary to follow all local electro technical regulations. The mains voltage and frequency must comply with the data stated on the device label.



Risk of fire and electric shock.
Electrical cord must not be broken.

Ethernet network connection

The dryer may be connected to an Ethernet 10/100 M network via the controller as follows:

- Use the RJ-45 connector on the switchboard door to connect a cable to the Ethernet network. (Fig. 15).
- Configuration of the IP address to connect to the local network:

- The default IP address of the BM module is: 192.168.0.3., TDE=192.168.0.2, sub-mask=255.255.255.0..
- The user shall request the configuration of IP addresses (specific

or requested) from the manufacturer before the compressor is shipped, or configure the IP addresses (specific or requested) based on the manual (see the service manual) or via the compressor manufacturer’s technical support for such purposes.

Fig. 15: Ethernet network connection

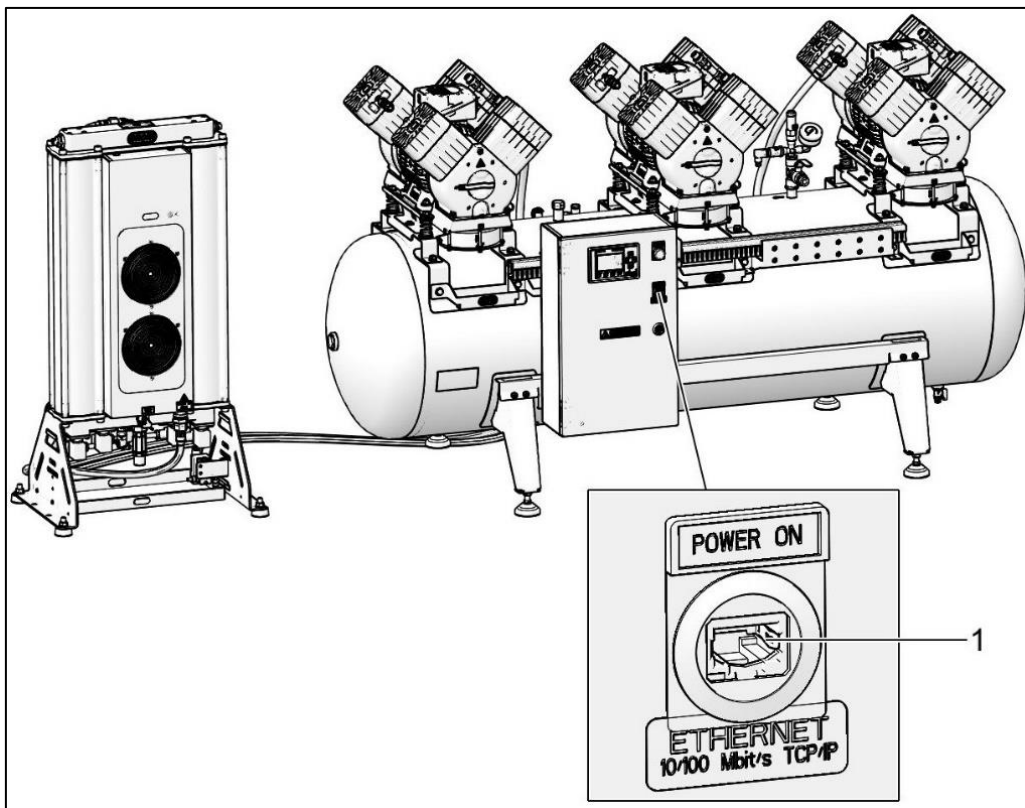

Web Server

The controller of dryer has an integrated Web Server function that facilitates compressor monitoring via a PC, smartphone or tablet using a conventional web browser (Firefox,

Opera, Safari, Google Chrome , etc /

The process for logging into the Web Server function once the compressor is connected to an Ethernet network is as follows:

- Open the web browser on a PC, smartphone or tablet and enter the IP address of the controller basic module (192.168.0.3).



- Enter the password “LOGO” and click on the “LOG on” button.



- After logging in, the browser displays the first screen showing the system information for the controller itself: module generation, model, firmware (FW), IP address and activity status.



- Click on the “LOGO! BM” function in the browser to display the current virtual status of the BM text display screen. Navigate through the screen using the cursor keys the same as on the real display.



13. COMMISSIONING

- Make sure all transport stabilizers were removed.
- Check that all compressed air connections are correct (see chap. 11).
- Check correct connection to the mains (see chap. 12).
- Check to ensure the connection cable is properly connected on the dryer. (Fig. 13)
- Check to ensure the outlet valve is in the OFF position.



The compressor is not equipped with a backup power supply.

14. PNEUMATIC DIAGRAM

DK50 3x4VR/M

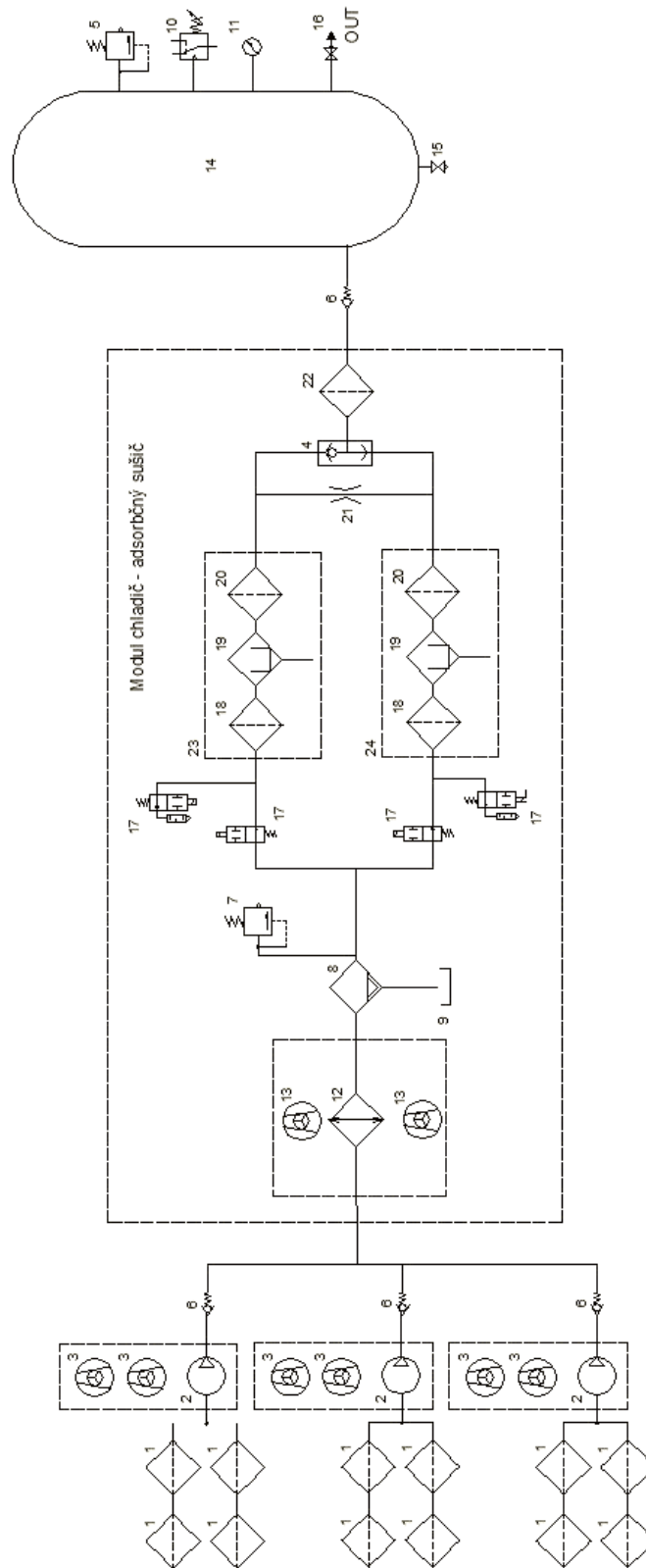

Description to pneumatic diagram:

1	Inlet filter	13	Cooler fan
2	Compressor	14	Air tank
3	Fan	15	Condensate drain valve
4	OR logic valve	16	Outlet valve
5	Safety valve	17	Dryer solenoid valve
6	Non-return valve	18	Chamber inlet filter
7	Pressure valve	19	Adsorbent
8	Condensate separator	20	Chamber outlet filter
9	Condensate collection vessel	21	Regeneration jet
10	Pressure sensor	22	Outlet filter
11	Pressure gauge	23	Chamber left
12	Cooler	24	Chamber right

OPERATION

**ONLY TRAINED PERSONNEL
MAY OPERATE THE
EQUIPMENT!**



Risk of electric shock.

In case of emergency, disconnect the compressor from the mains (pull out the mains plug).



Burn or fire hazard.

Portions of the air pump and compressed air components between the air pump and the air cooler may be hot and reach hazardous temperatures during compressor operation that may harm materials or operating staff.



Warning – compressor is controlled automatically.

Automatic start. The compressor automatically switches on when pressure in the air tank drops to the pressure switch's lower limit level. The compressor automatically switches off after reaching the pressure switch's upper limit level.



Potential for damage to pneumatic components.

The working pressure settings for the pressure switch set by the manufacturer cannot be changed. Compressor operation at a working pressure below the switching pressure indicates high air usage (see the Troubleshooting chapter).



Risk of damage to the dryer

The dryer may suffer damage if operated at ambient temperatures above its maximum working pressure as specified in the Technical Data chapter.



Required drying performance can only be achieved when following the defined operating conditions.

Drying performance will decline and the achieved dew point will drop if the dryer is operated at any pressure below the minimum working pressure.

15. SWITCHING ON THE COMPRESSOR

- Turn the main switch into the “I” position on the compressor switchboard. A message

appears on the display on the door of the switchboard, the display shows: RUN MODE or STAND-BY MODE

- MOTORS : OFF or ON
- TOT.HOURS: total time the compressor has been energised
- HOURS RUN: operating hours (motors on)
- TIME-TO-GO MN - time to the next maintenance / service work (in hours).
- SERVICE COMP: number of 2,000 h maintenance checks performed on the compressor.
- PRESSURE: current pressure

R U N M O D E											
T	O	T	A	L	H	R	S			0	h r s
										0	h r s
P	R	E	S	S	U	R	E	:		4	. 7 4 b a r
M	A	I	N	T	E	N	A	N	C	E	2 0 0 0 h r s

The first air pump automatically turns on and the other air pump then sequentially turn on. The pressure sensor monitors the pressure in the air tank.

The air pumps operate in automatic mode, and are switched on and off (see the section on working pressures in the Technical Data chapter) by the controller depending on compressed air usage. The compressors sequentially turn off once the switching pressure is reached.

The pressure sensor monitors the pressure in the air tank. The pressure value is shown on the display.



Check all air line connections and check for compressed air leaks. Remedy all leaks that are identified.

Slowly open the outlet valve to the ON

position. The compressor assembly starts and runs until pressure in the entire compressed air system stabilises. The air pumps then gradually turn off at the switching pressure.

Complete a record for the installation of the compressor assembly and commissioning. (see Annex)

Normal operation

Air pumps operate in automatic mode and are switched on and off based on demand for compressed air. When the pressure in the air tank drops to the switching pressure, the compressors automatically switch on in a sequence. This ensures that the required pressure is delivered to the air tank in the shortest possible time.

The display shows the following during normal operation of the equipment:

OPERATION

- TOT.HOURS total time the compressor has been energised
- HOURS RUN: operating hours (motors on)
- TIME-TO-GO MN - time to the next maintenance / service work
- SERVICE COMP: number of 2,000 h maintenance checks performed on the compressor.
- PRESSURE: current pressure

S T A N D - B Y M O D E			
T O T A L	H R S	0	h r s
R U N	H R S	0	h r s
P R E S S U R E :		8 . 0 0	b a r
T I M E - T O - G O			
M A I N T E N A N C E		2 0 0 0	h r s

Shutting down the compressor

Rotate switch Q10 to the “O” position to

disconnect the compressor from the mains. The green P1 indicator should turn off.

16. AD DRYER OPERATING MODES:

„RUN“ mode

The dryer is in “RUN” mode when the control signal from the compressor is active. The cooler fans are activated and the chambers

are cyclically switched by the solenoid valves based on the following time diagram T. This is the chamber switching period, and dT represents the pressure balancing time in the chambers prior to switching.

Valve switching schedule – “RUN” mode

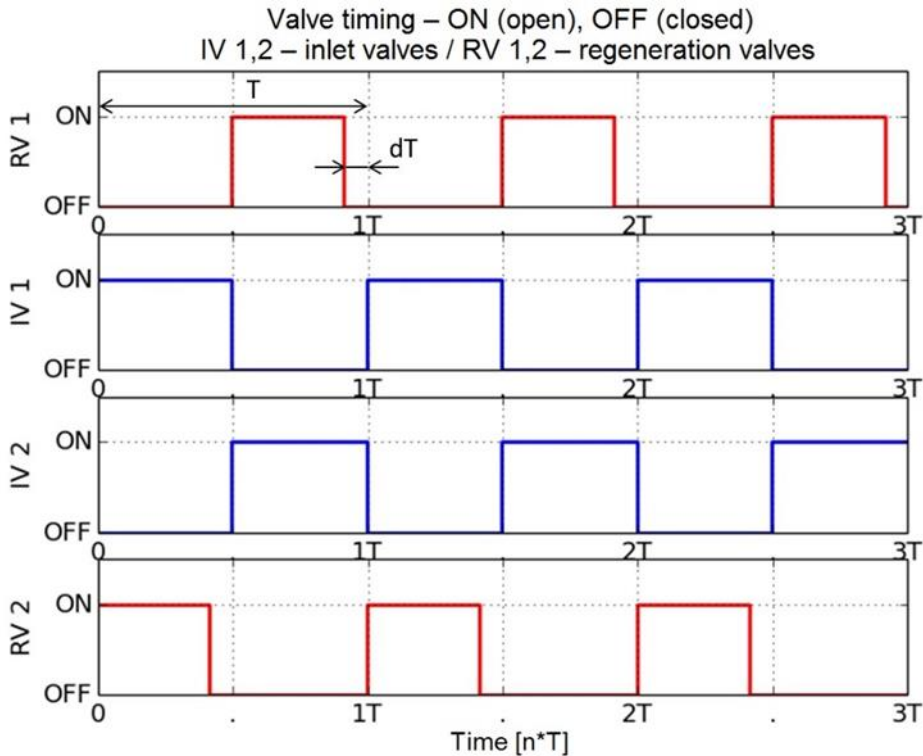

„STANDBY“ mode

The dryer is in “STANDBY” mode when the

control signal from the compressor is inactive. The cooling fans are off and chamber switching is deactivated.

Indication of an upcoming service interval

- 100 hours prior to the next service interval, the back lighting changes from white to orange and the display shows the message “SERVICE DUE IN XY HOURS”, where XY indicates the remaining number of hours until service is due.
- RUN HRS – total dryer cycling time (RUN mode)

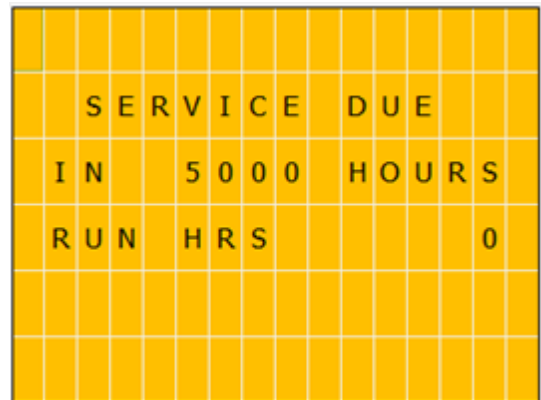

16.1. Controller description

The controller controls the air pumps, monitors their operation, analyses faults, reports alarms and indicates when maintenance is required after defined intervals are met.

The controller monitors operating pressure

and operating hours.

These values, alarms and service interval information are shown on the display.

The control panel on the controller has four cursor buttons ▲, ▼, ►, ◀, ESC and OK buttons, and four function buttons F1-F4, which trigger the following:

- F1-** display backlight
- F2-** information on operating hours and maintenance intervals
- F3-** statistics on the number of motor circuit breaker trips from motor overcurrent above defined motor circuit breaker limi
- F4-** SERVICE TECHNICIAN BUTTON (after completing service or maintenance work - hold for 5 seconds to reset the 2,000 hour maintenance interval)

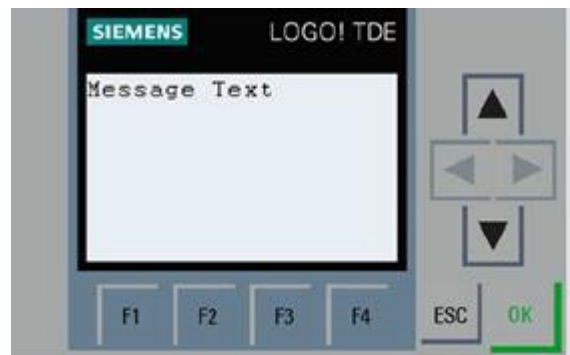

16.2. Equipment operation

Normal operating mode is shown when the

equipment is operating and the functional and control buttons are used to browse through the following:

Pressing **F2**:

TOT.HOURS: total time the compressor has been energised

HOURS RUN: operating hours (motors on)

TIME-TO-GO MN - time to the next maintenance / service work

SERVICE COMPR: number of 2,000 h maintenance checks performed on the compressor

SERVICE DRYER: number of dryer maintenance checks (every 12,000 hours)

M A I N T E N A N C E :			
T O T . H O U R S :	0	h	0 m
H O U R S R U N :	0	h	0 m
T I M E - T O - G O M N :	2 0 0 0	h	
S E R V I C E C O M P R			0 x
S E R V I C E D R Y E R			0 x

Pressing **F3**:

Displays the number and duration of overload faults for motors M1 to M3 (motor circuit breaker disconnects the motor from power). Circuit breakers must be manually turned to the ON position after remedying the malfunction.

F A I L U R E S			
M O T O R S T A R T E R :			
M 1	0	x	
M 2	0	x	
M 3	0	x	

Pressing **F4**:

F4 is only active if the maintenance screen appears once 2000 hours of operation have been passed (see the maintenance alarm). Press and hold F4 for at least 5 seconds to set a new interval. The screen switches back to normal operating mode once the new interval is set.

Note: Only service personnel are authorised to configure a new service interval using the **F4** button.

M A I N T E N A N C E	V 1 . 0 2
T O T A L H R S	0
R U N H R S	0
T I M E - T O - G O	
M A I N T E N E N C E	2 0 0 0 h r s
N U M B E R O F (M N)	0

16.3. Alarms



The equipment has an intelligent monitoring system that generates an alarm signal based on priority (medium priority alarms have higher priority than low priority alarms).



Alarm signals have a higher priority than maintenance/service interval signals.

Low priority alarm conditions

- Expiry of defined maintenance / service interval.

OPERATION

This alarm activates once the 2,000 hour maintenance / service interval expires. The display shows the following details:

SERVICE ACCORDING TO THE INSTRUCTIONS FOR USE

The display flashes orange.

The compressor supplies air to the compressed air system as needed and without restriction.

Call in service personnel to perform the required service.

Note: Only service personnel are authorised to configure a new service interval.

Press F4 and hold for at least 5 seconds to confirm the completion of maintenance / service.

The display then changes to the normal operating mode screen.

This indicates the new maintenance interval has been set on the controller from this time forward.



Any maintenance or service work must be recorded in the compressor's service log.

- Low pressure alarm during compressor start-up.

PRESSURE - current pressure in the system

HOURS RUN – operating hours

The information on the display automatically disappears once air pressure is above 5 bar.

The compressor supplies air to the compressed air system as needed and without restriction.

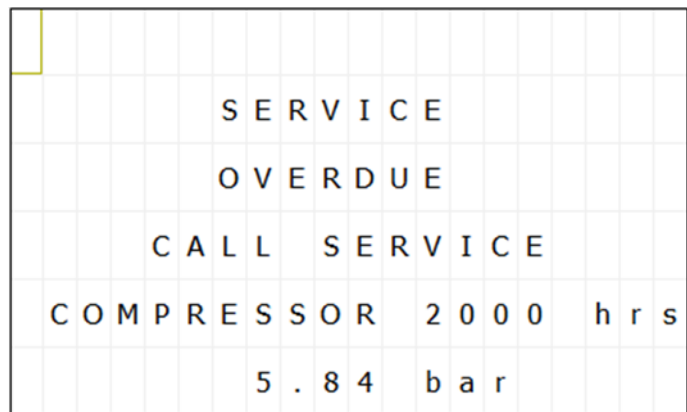

Medium priority alarm conditions

- Air pump malfunction

The message on the display (FAULT) and blinking ALARM indicator indicate which aggregate is not running (a motor circuit breaker (Q1 - Q3) is tripped due to current overload). The display flashes red.

The other aggregates are working normally.

The screen disappears once the malfunction is remedied and the motor circuit breaker is manually placed back in the "ON" position. The display for normal operation is shown.

- The compressor supplies compressed air to the central line through the functional air pumps.

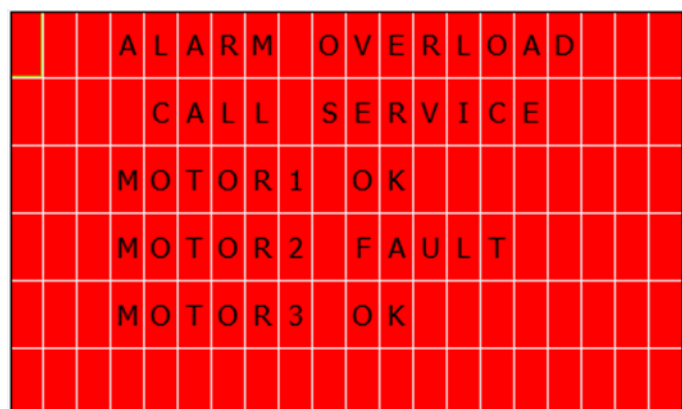

- Fault - motor winding temperature fault

The message on the display (ERROR) and blinking ALARM indicator indicate which of the aggregate motors has malfunctioned (open thermal overload switch (B11 - B13) inside the motor winding (M1 - M3). The malfunction in the air pump may be mechanical or electrical.

Once the malfunction is remedied (cooling, repair or replacement; the thermostat must be on), the ALARM indicator turns off and the display no longer shows the alarm.

			A	L	A	R	M		O	V	E	R	L	O	A	D			



Medium priority alarm signals have priority over maintenance interval signals.

As such, the light will indicate an alarm from any of the air pumps.

17. SWITCHING OFF THE COMPRESSOR

- Use the main switch, Q10, to switch off the compressor for maintenance or other reasons; the switch also functions as a central stop button. The compressor is disconnected from the mains with the exception of the mains terminal block X0.

Attention:

- Power terminals X0 remain energised even when main switch Q10 is in the "0" (off) position.

- Vent the air tank by disconnecting from the central compressed air circuit and opening the outlet valve (7) (Fig. 1) or the drain valve.

Switching off the AD dryer

- Turn off the compressor per the previous chapter.
- Open the venting plug (Fig. 20) to vent the pressure in the dryer chambers.

PRODUCT MAINTENANCE

18. PRODUCT MAINTENANCE



The operator should carry out device checks regularly in the intervals defined by applicable regulations. Test results must be recorded.

The equipment has been designed and manufactured to keep maintenance to a minimum. The following work must be performed to preserve the proper and reliable operation of the compressor.



Unauthorised interference hazard.

Repair work outside the framework of standard maintenance (see Chapter 18.1) may only be performed by a qualified technician (an organisation authorized by the manufacturer) or the manufacturer's customer service.

Standard maintenance work (see Chapter 18.1) may only be performed by the operator's trained personnel.

Only use manufacturer-approved replacement parts and accessories



Danger of injury or equipment damage.

Prior to commencing compressor maintenance, it is necessary to:

- check if it is possible to disconnect the compressor from the appliance in order to avoid any risk of injury to the person using the appliance or other material damage;
- turn off the compressor;
- disconnect it from the mains (pulling the cord out of the mains socket);
- vent the compressed air from the air tank.

Prior to commencing dryer maintenance work, first:

- turn off the compressor and disconnect it from the mains
- check the pressure indicator on the dryer and if there is still pressure, it must first be vented from the dryer chamber



Venting compressed air poses an injury hazard.

Wear eye protection, i.e. goggles, when venting compressed air from the compressed air circuit (air tank) and from the dryer chamber.

**Burn hazard.**

When the compressor is running or shortly thereafter, certain portions of the air pump and parts of the dryer may be hot - do not touch these components.



The removed grounding conductor during service must be connected back to the original position after completing the service.

18.1. Maintenance intervals

Time interval	Performed by		qualified technician					
	operator							
50 Hz								
Check of product operation	x	x						
Pour the trapped condensate out of the container								
Check of pneumatic connections leakage and device inspection			x	x	x	x	x	x
Inspection of electrical connections			x	x	x	x	x	x
Check of non-return valves function								
Check the function of pressure sensor B1			x	x	x	x	x	x
Check of pressure relief valve								
Check the switching function of thermostat B2			x	x	x	x	x	x
Once a day								
Once a week								
Once a year								
Once every 2 years								
2000 hours			x	x		x	x	x
4000 hours			x	x	x	x	x	x
6000 hours			x	x		x	x	x
8000 hours			x	x	x	x	x	x
10000 hours			x	x		x	x	x
12000 hours			x	x	x	x	x	x
24000 hours			x	x	x	x	x	x
Chap.	18.2	18.5	18.3	18.4	18.8	18.11	18.20	18.10
Set of replacement parts	-	-	-	-	-	-	-	-

18.2. Check of product operation

- Check air pump condition – the air pumps should be operating normally without excessive vibration or noise. Troubleshoot any problem or call in service personnel if trouble is detected.
- Visually inspect fan operation – the fans must be operating when the aggregates are running. Troubleshoot any problem or call in service personnel if trouble is detected.
- Check to ensure the power cord, the connecting compressed air hoses are undamaged. Replace damaged components or call in service personnel.
- Check the ambient temperature – the ambient temperature must be below the temperature limit (40°C). Cool the space if the temperature is high.
- Check for alarm conditions on the display – troubleshoot and remedy all alarms.
- Check the operating condition of the equipment (see Chapter 18.4).

18.3. Check the compressed air connections for leaks and inspect the equipment

Leak testing

- Check the compressor's compressed air lines for leaks during operation – pressure supplied by the compressor.
- Use a leak analyser or soapy water to check all joints and connections for leaks. Tighten or reseal the connection where leaks are found.

Inspecting the equipment

- Check the condition of the compressor air pump for normal operation and noise levels.
- Fan operation check – the fans must be running during the defined compressor work cycles.
- Check filters condition – filters must be undamaged and sufficiently clean.
- Check condition of the pump itself, check if there is no dirt inside the crankcase or

clearance in the crankshaft.

- Check the functionality of the automatic condensate drain.
- Replace any defective parts as needed.
- Check the solenoid valves in the valve module – the valves should cyclically cycle between the chambers based on the description of the operation.
- Check the operating condition of the equipment (see chap. 18.4).

18.4. Inspection of electrical connections



Risk of electric shock.

Inspect the product's electrical connections when the mains are disconnected.

- Check mechanical function of the main switch.
- Check if the power cable and conductors are not damaged.
- Visually check if cables are connected to the terminal box.
- Check all screw connections of the green-yellow PE grounding conductor.
- Check the mechanical function of the main switch Q10
- Check the power cord, conductors connected to the X1 terminal strip and the main switch to ensure they are undamaged. Inspect to ensure the connection terminals are properly supported to relieve tension.
- Check to ensure all threaded conductor terminals are tight (on motor circuit breakers Q1-3, main circuit breakers F1, contactors Q11-13, etc.). Tighten all loose terminals with a screwdriver.
- Visually inspect the connection of individual cables to the terminal strip X1 (spring clips) and the LOGO! control system (screw terminals).
- Inspect all screw terminals for the protective green and yellow PE grounding conductors in the switchboard, the motor section, the cooling unit and the pressure

vessel. Tighten any loose terminals.

- Inspect the connector and pressure sensor B1 (on the air tank).

Checking the operating condition of the AD dryer

- Check the service indicator and alarms on the display screen as specified in Chapter 0 and schedule service or repairs as needed.
- Only a service technician is permitted to modify program parameters using the cursor buttons on the LOGO! module and only after a password is entered.
- The operator may monitor the individual values on the display but has no access to the parameters of the program.

Indication of an upcoming or expired

service interval

Configuration of a new service interval

Press ESC + ► together and hold for 10 seconds to reset the service interval. Once complete, the display returns back to the home screen.

The SET UP function for a new service interval is only functional if the dryer indicates an upcoming service interval or that a service interval has expired. Once complete, the MAINT counter increases (number of completed service operations) by one. See the screen: Counters.

Information screens – version AD750 E

Information screens are activated by simultaneously pressing and holding down the ESC key and cursor buttons.

- ESC+◀- „COLUMNS TIMING“ screen

- Information about the defined valve cycling times
- INLET_A(INLET_B) – duration of the adsorption phase (half-cycle) for chamber A (chamber B)
- PURGE_A(PURGE_B) – duration of the regeneration phase for chamber A (chamber B)

C O L U M N S	
T I M I N G	
P U R G E _ A =	1 0 0 s
I N L E T _ A =	1 2 0 s
I N L E T _ B =	1 2 0 s
P U R G E _ B =	1 0 0 s

- ECS+▼ – „COUNTERS“ screen

- Information about counters, the number of times service has been performed and the number of times the solenoid valves have been activated
- MAINT – number of service operations
- VALVE – number of times the solenoid valves have been activated (the number displayed indicates the number of times the Inlet_A inlet valve into chamber A has been activated)
- Version – software version

C O U N T E R S :	
M A I N T	0 x
V A L V E	4 x
V e r s i o n	V 3 . 0 0

• ESC+▲– „OPERATING TIME“ screen

- information on operating hours: TOTAL, RUN, STAND BY, time remaining to the next service interval and value of the defined service interval
- TOTAL HRS – total time the dryer has been energised
- RUN HRS – total dryer cycling time
- STAND.HRS – total time in STAND BY mode
- TIME-to-MT – time remaining to the next service interval
- SERV.INTER – value of the defined service interval

T	O	T	A	L	H	R	S		0											
					R	U	N	H	R	S		0								
					S	T	A	N	D	.	H	R	S		0					
					T	I	M	E	-	t	o	-	M	T		1	h			
					S	E	R	V	.	I	N	T	E	R		0	h			
					S	E	T	U	P	=	E	S	C	+	▶	/	1	0	s	/

- ESC+▶ (press and hold for 10 seconds) – to configure a new service interval once a service operation is complete (see above – Configuration of a new service interval).



Switch off the compressor every time before emptying the vessel!

18.5. Condensate drain



A wet floor resulting from overflow from the vessel poses a slip hazard.

The volume of the collection vessel must not exceed the defined maximum level.

Regularly empty the condensate collection vessel.

Condensate is automatically drained into a vessel to collect condensate.

- Monitor the level in the vessel using the markings (depending on the volume of the vessel), and empty at least once a day.

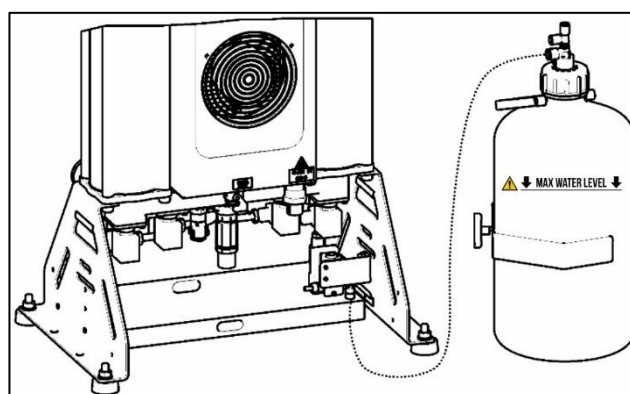

Fig. 16: Check of the condensate collection vessel

18.6. Inlet filter replacement

Inlet filter replacement:

- Pull out the rubber plug by hand (2).
- Remove the dirty intake filter (1).
- Insert a new filter and replace the rubber plug.

Pre-filter replacement:

- Pull out the pre-filter by hand (3).
- Replace with a new one and insert it back.

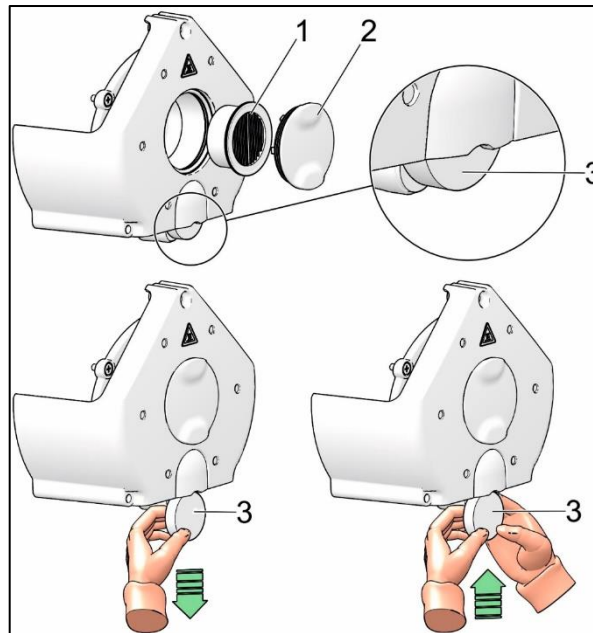

Fig. 17: Inlet filter replacement

18.7. Check of safety valve

- Turn the screw on the safety valve several times to the left until the safety valve releases the air.
- Let the safety valve vent for a few seconds.
- Turn the screw fully to the right, the valve must be closed now.

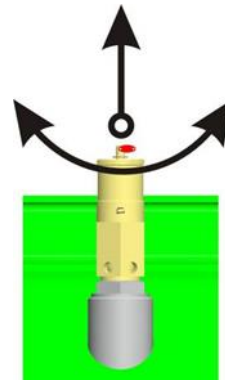

Fig. 18: Check of safety valve



Damage to the safety valve could cause pressure to rise to hazardous levels.

Never use the safety valve to release the air pressure in the air tank. This could damage the safety valve. The valve is set to the maximum permitted pressure by the manufacturer.

Never adjust a safety valve.



Venting compressed air poses an injury hazard.

Wear safety glasses when inspecting a safety valve.

18.8. Check of non-return valves function

Check for proper operation of the non-return valves (3) (Fig. 1) in the pneumatic circuit by disconnecting the pressure hoses from the air pumps.



One air pump must be operating, shut off the remaining air pumps at the current protection device (25) in the switchboard. No air may leak through the non-return valves.

Check for proper operation of the non-return valve (31) on the air tank by disconnecting the pressure hose from the valve



Inspect the non-return valve once the air tank is pressurised and the compressor is off. No air may leak.

18.9. Check operation of solenoid valves

Valve functionality is checked using the “Magnetic indicator” as follows:

- Place it on the valve coil.
- if the motors are active, the indicator must turn
- If not, the indicator does not turn.

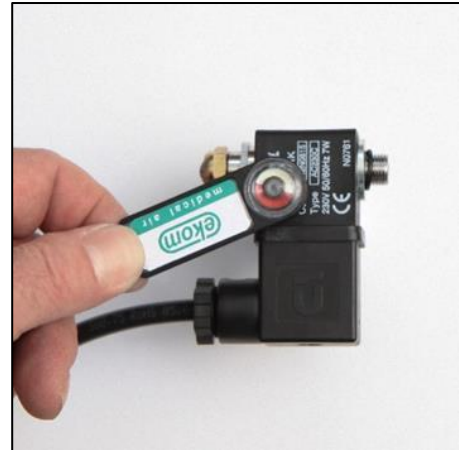

Fig. 19: Solenoid valve M10

18.10. Check the switching function of thermostat B2

Check of operation – if the motors are off and the ambient temperature around B2 is higher than 40°C, then fan motors E1-E6 must run to cool the motors

18.11. Check the function of pressure sensor B1

Functionality is checked visually using the TDE screen, which shows the compressed air value. Changes in air usage must be reflected in pressure changes on the display.

18.12. Cleaning and disinfection of the exterior surfaces of the product

Clean and disinfect the exterior surfaces with neutral cleaning products.



Use of aggressive detergents and disinfectants containing alcohol and chlorides can lead to surface damage and discolouration.

AD dryer maintenance

18.13. Venting pressure from the dryer

The equipment is designed to permit the safe venting of pressure within 10 seconds after the compressor is shut off.

If pressure is not automatically vented from the dryer, then the pressure may be vented manually.



Venting compressed air poses an injury hazard

Wearing hearing protection is recommended given the noise generated by the venting process.



Shut off the compressed air source before venting pressure from the equipment.

Venting pressure using the display screen

Press ESC+▼ in the display screen to vent pressure from the equipment.

- First, shut off the compressed air source.
- Then press and hold ESC+▼, which will open all the solenoid valves (inlet and regeneration) for 10 seconds and then vent the pressure from the equipment and connected pneumatic circuits and elements that are not separated from the

equipment by the check valve

Manual venting of pressure

- Turn off the compressor.
- Open the vent plugs on the outlet module on the equipment (Fig. 20).

Fig. 20: Venting pressure from the dryer chambers

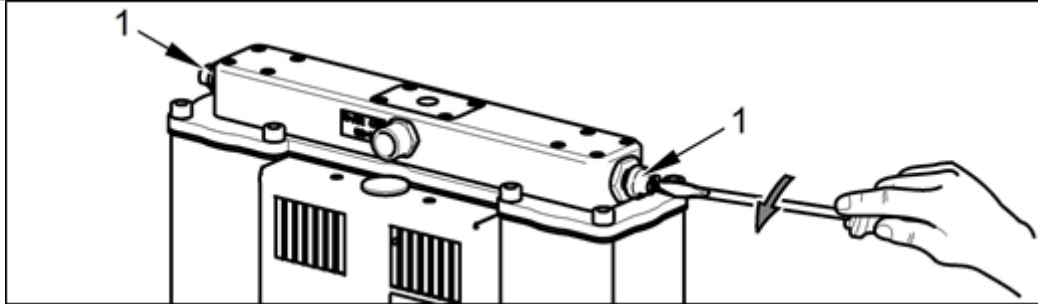

- Disconnect the hose (2) from the lower part of the condensate separator (3). (Fig. 21)

Fig. 21: Venting pressure from the cooler and condensate separator

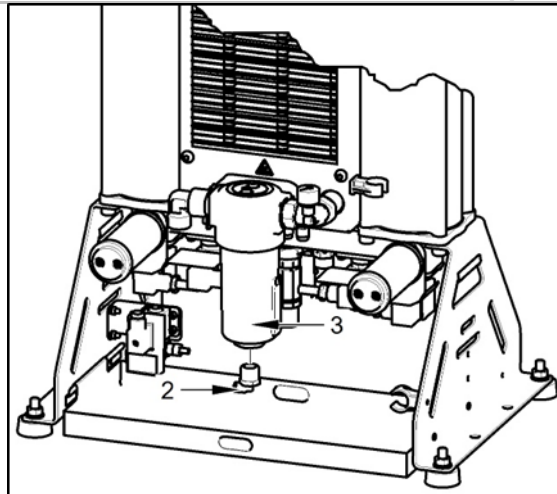

The process of manually venting pressure from the equipment is complete after approximately 2 minutes.

18.14. Replacement of the dryer's internal filters



Working with pressurised pneumatic components poses a risk of injury.

Prior to any work, disconnect the equipment from the mains, shut off the compressor and vent all pressure in the equipment to zero.

In normal operation, filter replacement must be performed in the upper part of the dryer at the defined interval.

- Turn off the compressor.
- Check the pressure in the dryer.
- If the dryer chambers are under pressure, proceed in accordance with Chapter 18.13.
- Unscrew the 8 screws (1).
- Disassemble the outlet panel (2) on which the filters (3) are mounted.
- Unscrew the dirty filters (3) and replace with new filters.
- Check the seal (4) on the bottom of the outlet module and replace if necessary.
- Reverse the procedure to reassemble.
- Switch on the compressor.
- Check for any dryer leaks.

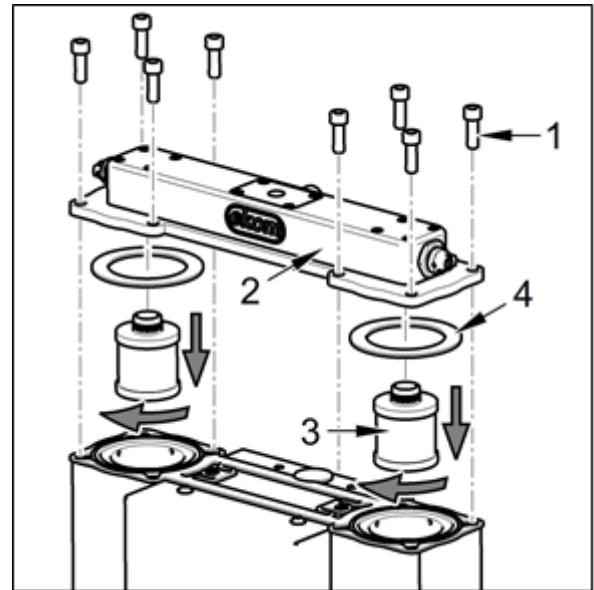

Fig. 22: Replacement of internal filters

18.15. Replacement off cassettes with adsorbent media

In normal operation, the replacement of the cassettes with adsorbent media must be performed at the defined interval.

- Turn off the compressor.
- Check the pressure in the dryer.
- If the dryer chambers are under pressure, proceed in accordance with Chapter 18.13.
- Unscrew the 8 screws (1).
- Remove the outlet panel (2).
- Pull out and replace the cassettes (3) with new parts.
- Check the seal (4) on the bottom of the outlet module and replace if necessary.
- Reverse the procedure to reassemble.
- Switch on the compressor.
- Check for any dryer leaks.

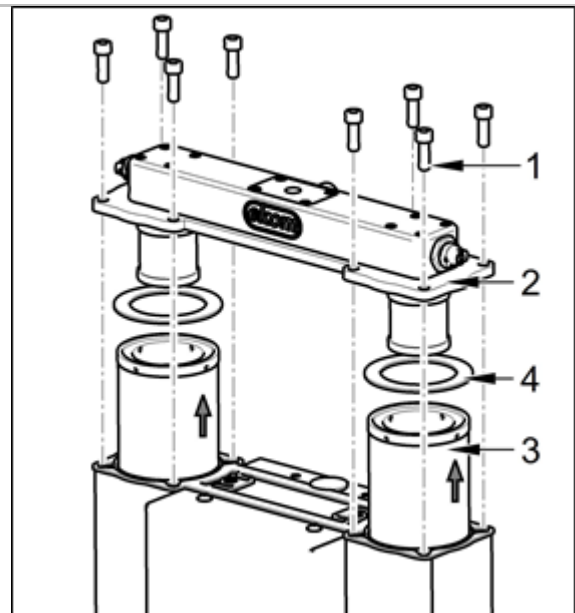

Fig. 23: Replacement of cassettes with adsorbent media

18.16. Replacement of the logic valve ball

- Turn off the compressor.
- Check the pressure in the dryer.
- If the dryer chambers are under pressure, proceed in accordance with Chapter 18.13.
- Unscrew the 4 screws (1) and remove the cover (2).
- Remove the ball cover (3).
- Replace the ball (4).
- Check the nozzles (5) and clean as necessary.
- Reverse the procedure to reassemble.
- Check for leaks and the operation of the logic valve and nozzles – check for the cyclical switching of the chambers.

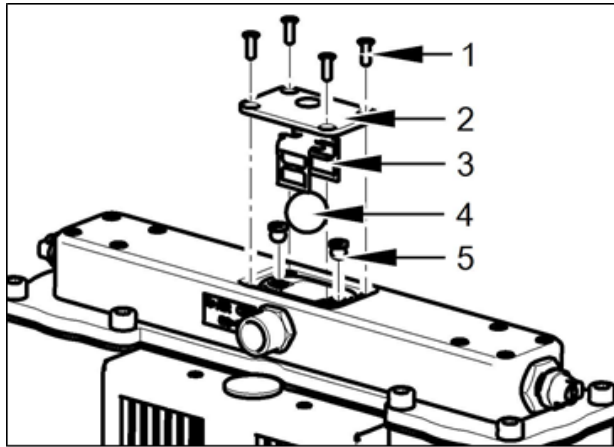

Fig. 24: Replacement of the logic valve ball

18.17. Replacement of the dryer's silencer



Working with pressurised pneumatic components poses a risk of injury.

Operating the equipment without silencers generates high levels of noise. Only replace silencers when the equipment is shut down.

- Unscrew the silencer (1).
- Install a new silencer.

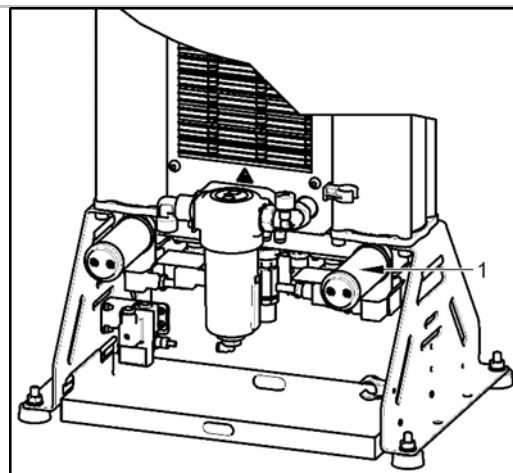

Fig. 25: Replacement of the silencer

18.18. Inspecting the cooled and fan

The equipment, in particular the compressor fan, cooler fan, and the cooler, must be kept clean to ensure efficient drying. Remove dust from the surface of the cooling fins and fans by vacuuming or blowing down with compressed air.

18.19. Replacement of solenoid valves



Risk of electric shock.

Shut off the compressed air source, turn off the equipment and disconnect it from the mains before working on the equipment.



Working with pressurised pneumatic components poses a risk of injury.

Disconnect the equipment from the mains and vent the pressure in the equipment and the pneumatic system to zero before working on the equipment.

In normal operation, the solenoid valves in the bottom of the dryer must be replaced at the defined interval.

- Turn off the compressor.

- Check the pressure in the dryer.
- If the dryer chambers are under pressure, proceed in accordance with Chapter 18.13.
- Unscrew the 1 screw from the valve connector (1).
- Disconnect the valve connector (1).
- Unscrew the 4 screws (2).
- Remove the solenoid valve (3).
- Remove the valve seal (4-1) from the body. (Fig. 27).
- Physically clean the valve seat surface to remove any impurities.
- Physically clean the 16 screws to remove the thread locking adhesive.
- Install the solenoid valve (Fig. 27).
- The new valve seal (4-1).
- Install the new solenoid valve using the 4 screws (2) and use a thread locking adhesive on the threads of the screws (such as Loctite 243).
- Reattach the solenoid valve connector and attach with a screw.
- Switch on the compressor.
- Check for any dryer leaks.

Fig. 26: Solenoid valve replacement

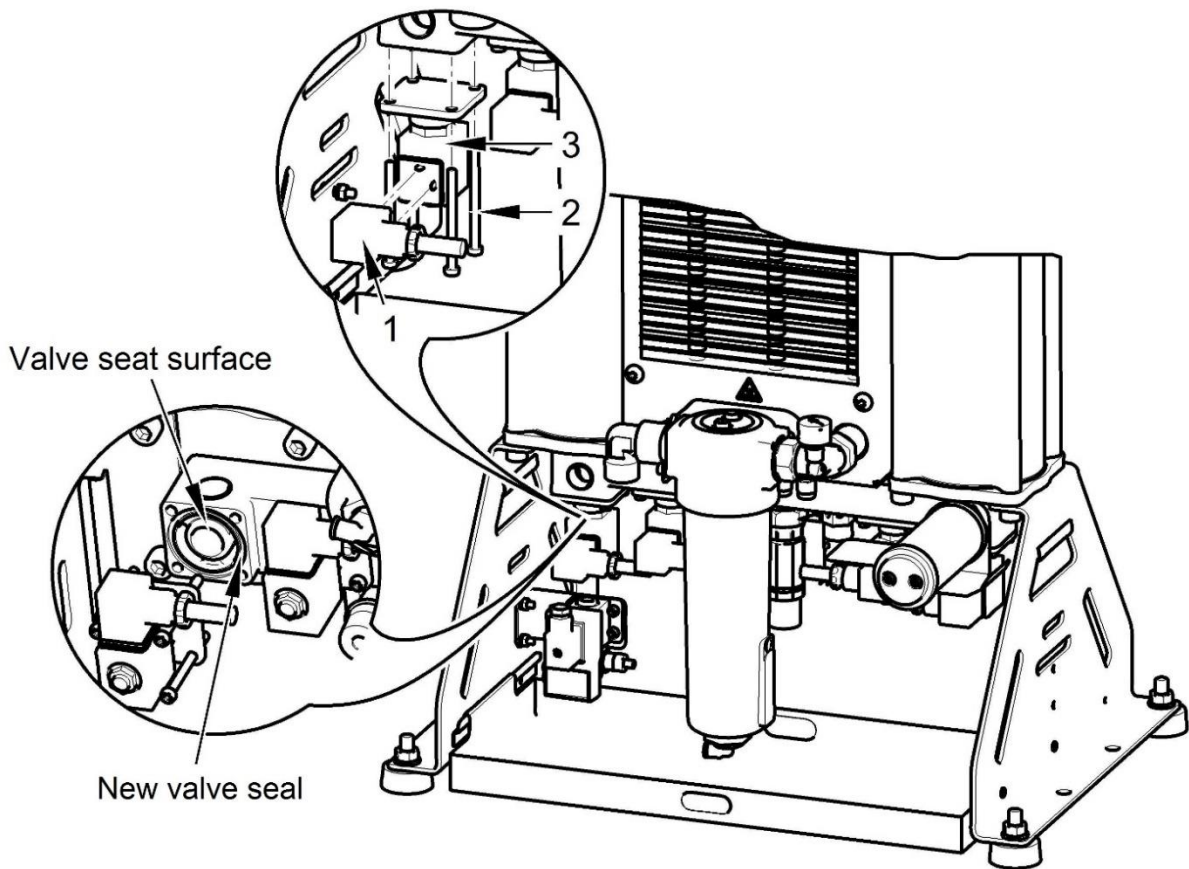

Solenoid valve assembly

Replacement solenoid valves are delivered as disassembled replacement parts. The new valve must be assembled before a solenoid valve is replaced.

- Mount the valve coil (4-5) onto the valve body (4-4) and secure with the nut (4-6).
- Insert the valve membrane spring (4-3) into the membrane (4-2) and the insert into the assembled valve coil and body assembly.
- Then mount the valve seal (4-1) onto the dryer body.

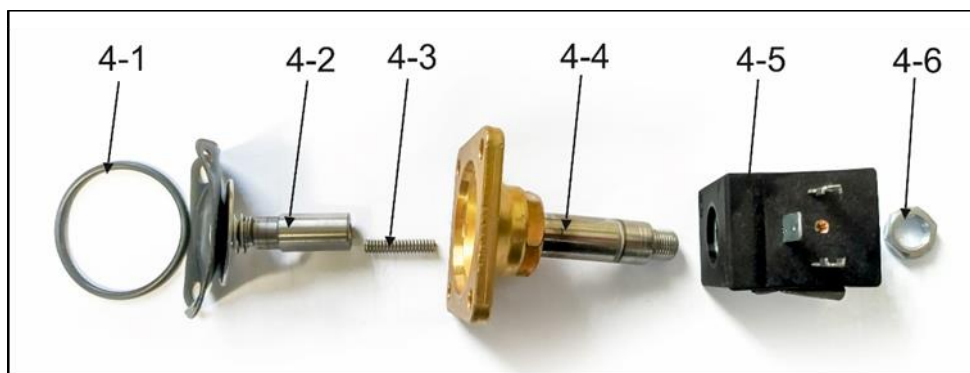

Fig. 27: Solenoid valve assembly

18.20. Pressure relief valve

The pressure relief valve automatically begins to vent air from the system if the pressure in the compressed air circuit exceeds its pre-set value. The pressure relief valve closes as the pressure drops.



The pressure in the compressed air circuit can only increase because of an increase in flow resistance in the compressed air lines or as a result of a dryer malfunction (e.g. solenoid valve malfunction), and therefore the repeated opening of the relief valve requires a dryer function check and repairs if necessary!



Consultation with the manufacturer is required before any adjustment is made to the relief valve!

The outlet openings on the relief valve may not be blocked and the egress of compressed air through them may not be restricted.

1 Compressor pressure relief valve

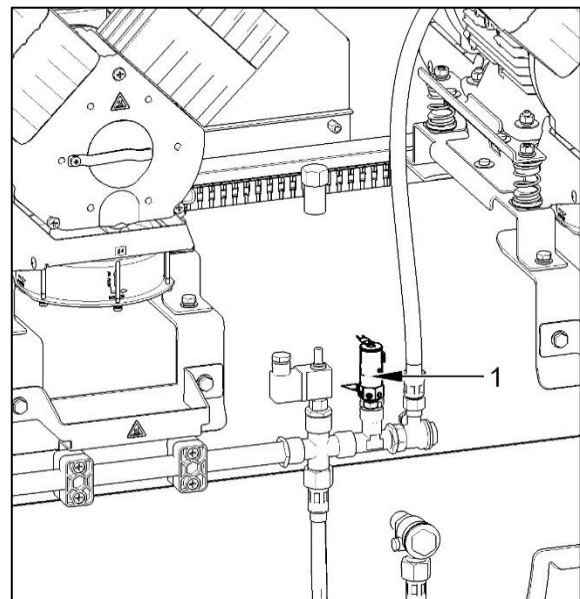

2 Dryer pressure relief valve

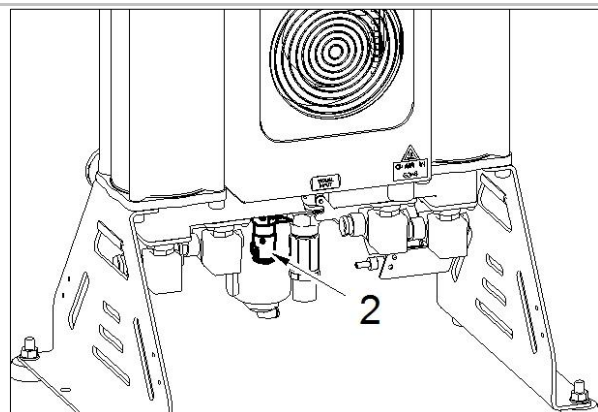

Fig. 28: Pressure relief valve

19. LONG-TERM SHUTDOWN

If the compressor is not going to be used for long period, it is recommended to drain all condensate from the air tank and switch on the compressor for about 10 minutes, keeping the drain valve open (7) (Fig. 1). Thereafter

switch off the compressor using the switch (2) on the pressure switch (1) (Fig. 20), close the drain valve and disconnect the device from the mains.

20. DISPOSAL OF DEVICE

- Disconnect the equipment from the mains.
- Release the air pressure in the pressure tank by opening the drain valve (7) (Fig. 1), release the air pressure from the dryer chambers (Fig. 20).
- Dispose of the equipment following all applicable regulations.
- Entrust a specialised company to sort and dispose of waste.
- Worn out components have no negative environmental impact.

TROUBLESHOOTING



Risk of electric shock.
Before interfering with the equipment, first disconnect it from the mains (remove the power socket).



Working with pressurised pneumatic components poses a risk of injury.
Before interfering with the equipment, vent the air tank and the compressed air system to zero pressure.



Troubleshooting may only be performed by a qualified service technician.



Damage to the safety valve could cause pressure to rise to hazardous levels.
Never adjust a safety valve.

Malfunction	Possible cause	Solution
Compressor does not switch on	No voltage in the pressure switch	Check voltage in socket
		Check circuit breaker switch – switch to position switched-on „I“
		Loose conductor from terminal - repair
		Check electrical cord – replace defective cord
	Motor winding failure, damaged thermal protection	Replace motor or windings
	Capacitor failure	Replace capacitor
Compressor often switches on	Seized piston or other rotating part	Replace damaged components
	Pressure switch does not switch	Check function of pressure switch
	Controller malfunction	Check controller operation, check to ensure software is present - replace if damaged or upload the correct program
RUN/STOP indicator is not green	Loss of connection between controller and expansion module	Check connection – replace if damaged
	Power loss	Check mains voltage
		Loose terminal in switchboard - tighten
		Check the primary power connection - replace if damaged
	Problem with electrical power source	Main breaker is off
Controller or expansion module malfunction	Replace failed controller or expansion module	
Compressor often switches on	Air leakage in pneumatic system	Check pneumatic system – seal loose connections
	Non-return valve (SV) leakage	Clean non-return valve, replace seals, replace non-return valve
	Leak through solenoid valves once	Clean the check valve - replace if

	regeneration is complete	damaged
	Leak at pressure sensor and safety valve	Test their function and clean, or replace if damaged
Low pressure in the air tank (compressor running constantly)	High air consumption of supplied equipment	Decrease air consumption Use compressor with higher capacity
	Leakage in pneumatic system	Check pneumatic system – seal loose connections
	Low capacity of the pump	Clean / replace the pump
	Pump failure	Clean / replace the pump
	Dryer failure	Replace dryer
Prolonged operation of the compressor	Air leakage in pneumatic system	Check pneumatic system – seal loose connection
	Worn piston ring	Replace worn piston ring
	Dirty inlet filter	Replace dirty filter with new filter
	Incorrect function of solenoid valve	Repair or replace fan or coil
Compressor is noisy (knocking, metal noises)	Damaged piston bearing, piston rods, motor bearing	Replace damaged bearing
	Loose (cracked) dampening element (spring)	Replace damaged spring
High ambient temperature causes compressors to switch off in vertical stacks (overheating)	Lack of ventilation in compressor room	Secure suitable ambient conditions
	Cooling fans for aggregates, cooler and enclosure do not work	Defective fans - replace Defective temperature switch - replace
Degraded drying performance – high-pressure dew point (condensed water in the air)	Low operating pressure	Reduce the demand for air, check the output from the compressed air source, fix any leaks in the distribution system
	Regeneration solenoid valve not working	Check coil operation, replace if damaged Inspect the condition of the valve – clean the valve or replace if problems persist
	Air regeneration nozzle plugged	Clean or replace the nozzle (see product maintenance)
	Cooling fan not working	Check the power source to the fan Replace damaged fan
	Dirty cooler	Inspect the cooler and clean as necessary
	Silencer plugged at outlet from regeneration valve	Inspect the silencers. Clean or replace the silencer if flow resistance is too high or if heavily soiled.
Dryer emitting high levels of noise	Damaged fan	Replace damaged fan
	Damaged silencer	Replace the silencer
	Air leaking through relief valve at dryer inlet	Check the dryer connection to the mains and dryer connections, check the dryer operation, check the

		dryer's working pressure, and replace defective components.
Air leaking through relief valve at dryer inlet	High working pressure from air source	Check the pressure setting on the compressed air source
	Dryer inlet solenoid valve not working	Check the coil operation, replace if damaged
		Inspect the condition of the valve – clean the valve or replace if problems persist
High pressure in equipment resulting from plugged filters	Check the internal filters and accessory filter assemblies. Clean or replace dirty filters.	

Once a dryer fault is cleared and after its reassembly, the dryer should quickly be regenerated, best when using continuous compressor operation at a pressure of around 1 bar for a period of at least 1 hour; then check the dryness of the compressed air.



Check the moisture content of the air exiting the air tank (see the Technical data chapter) to prevent damage to connected downstream equipment.

21. REPAIR SERVICE

Warranty and post-warranty repairs must be done by the manufacturer, its authorized representative, or service personnel approved by the supplier.

The manufacturer reserves the right to make changes to the equipment without notice. Any changes made will not affect the functional properties of the equipment.

Attention.



DK50 3X4VR/M

 EKOM spol. s r.o.
Priemyselná 5031/18, 921 01 PIEŠŤANY
Slovak Republic
tel.: +421 33 7967 211, fax: +421 33 7967 223
e-mail: ekom@ekom.sk, www.ekom.sk

NP-DK50 3x4VR_M-AD-A-EN-9_11-2025
112000554-0001

www.ekom.sk